

AVR 134 Audio/Video Receiver

OWNER'S MANUAL

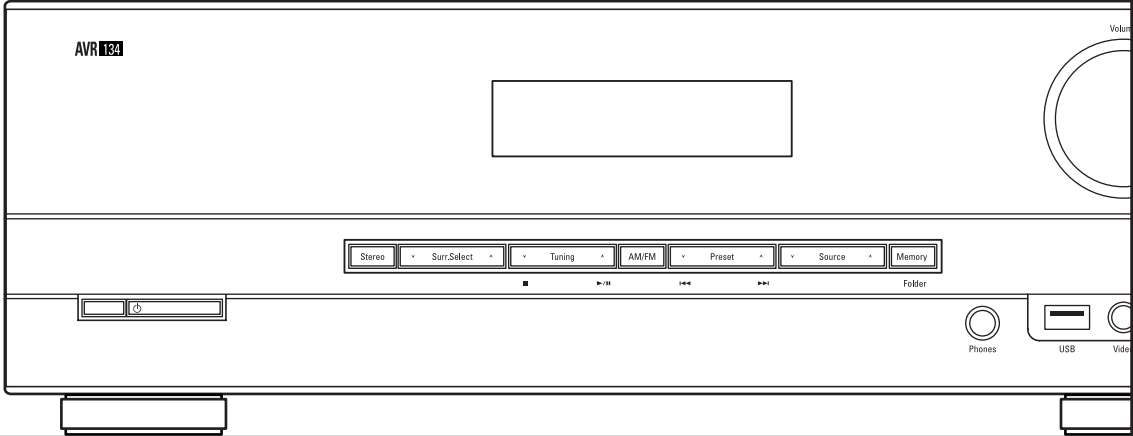

harman/kardon®

Introduction

READ THIS BEFORE OPERATING YOUR UNIT



CAUTION
RISK OF ELECTRIC SHOCK
DO NOT OPEN



CAUTION : TO REDUCE THE RISK OF ELECTRIC SHOCK, DO NOT REMOVE COVER (OR BACK). NO USER-SERVICEABLE PARTS INSIDE. REFER SERVICING TO QUALIFIED SERVICE PERSONNEL.



This symbol is intended to alert the user to the presence of uninsulated "dangerous voltage" within the product's enclosure that may be of sufficient magnitude to constitute a risk of electric shock to persons.



This symbol is intended to alert the user to the presence of important operating and maintenance (servicing) instructions in the literature accompanying the appliance.

WARNING : TO REDUCE THE RISK OF FIRE OR ELECTRIC SHOCK, DO NOT EXPOSE THIS APPLIANCE TO RAIN OR MOISTURE.

Caution regarding installation

Note : For heat dispersal, do not install this unit in a confined space such as a bookcase or similar enclosure.

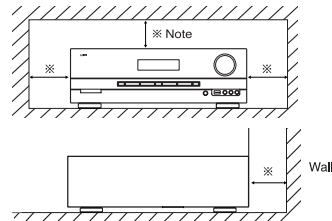

Do not block ventilation openings or stack other equipment on the top.

FOR YOUR SAFETY

EUROPE U.A.E	220 V	Units shipped to U.A.E are designed for operation on 240 V AC only. To ensure safe operation, the three-pin plug supplied must be inserted only into a standard three-pin power point which is effectively earthed through the normal household wiring. Extension cords used with the equipment must be three-core and be correctly wired to provide connection to earth. Improper extension cords are a major cause of fatalities. The fact that the equipment operates satisfactorily does not imply that the power point is earthed and that the installation is completely safe. For your safety, if in any doubt about the effective earthing of the power point, consult a qualified electrician. PAN-EUROPEAN UNIFIED VOLTAGE All units are suitable for use on supplies 220-240 V AC.
	240 V	

CAUTION

- Leave a space around the unit for sufficient ventilation.
- Avoid installation in extremely hot or cold locations, or in an area that is exposed to direct sunlight or heating equipment.
- Keep the unit free from moisture, water, and dust.
- Do not let foreign objects in the unit.
- The ventilation should not be impeded by covering the ventilation openings with items, such as newspapers, table-cloths, curtains, etc.
- No naked flame sources, such as lighted candles, should be placed on the unit.
- Please be care the environmental aspects of battery disposal.
- The unit shall not be exposed to dripping or splashing for use.
- No objects filled with liquids, such as vases, shall be placed on the unit.
- Do not let insecticides, benzene, and thinner come in contact with the set.
- Never disassemble or modify the unit in any way.
- Notes on the AC power cord and the wall outlet.
- The unit is not disconnected from the AC power source(mains) as long as it is connected to the wall outlet, even if the unit has been turned off.
- To completely disconnect this product from the mains, disconnect the plug from the wall socket outlet.
- When setting up this product, make sure that the AC outlet you are using is easily acceptable.
- Disconnect the plug from the wall outlet when not using the unit for long periods of time.

Information for Users on Collection and Disposal of Old Equipment and used Batteries



These symbols on the products, packaging, and/or accompanying documents mean that used electrical and electronic products and batteries should not be mixed with general household waste. For proper treatment, recovery and recycling of old products and used batteries, please take them to applicable collection points, in accordance with your national legislation.



By disposing of these products and batteries correctly, you will help to save valuable resources and prevent any potential negative effects on human health and the environment which could otherwise arise from inappropriate waste handling.



For more information about collection and recycling of old products and batteries, please contact your local municipality, your waste disposal service or the point of sale where you purchased the items.

Pb

[Information on Disposal in other Countries outside the European Union]

These symbols are only valid in the European Union. If you wish to discard these items, please contact your local authorities or dealer and ask for the correct method of disposal.

Note for the battery symbol (bottom two symbol examples):

The sign Pb below the symbol for batteries indicates that this batteries contains lead.

CONTENTS

Introduction

• READ THIS BEFORE OPERATING YOUR UNIT	2
--	---

System Connections

4

Front Panel Controls

10

Remote Control Functions

12

• FUNCTIONS LIST	14
• REMOTE CONTROL OPERATION RANGE	15
• LOADING BATTERIES	15

Operations

• LISTENING TO A PROGRAM SOURCE	16
• SURROUND SOUND	19
• ENJOYING SURROUND SOUND	20
• LISTENING TO RADIO BROADCASTS	24
• PLAYING MUSIC FILES(USB)	26
• RECORDING	29
• OTHER FUNCTIONS	31

System Setup

32

• SETTING THE SYSTEM	34
• SETTING THE INPUT	36
• SETTING THE SPEAKER SETUP	37
• SETTING THE CH LEVEL	40
• SETTING THE PARAMETER	42

Troubleshooting Guide

44

Specifications

44

System Connections

- Please be certain that this unit is unplugged from the AC outlet before making any connections.
- Be sure to observe the color coding when connecting audio, video and speaker cords.
- Make connections firmly and correctly. If not, it can cause loss of sound, noise or damage to the receiver.

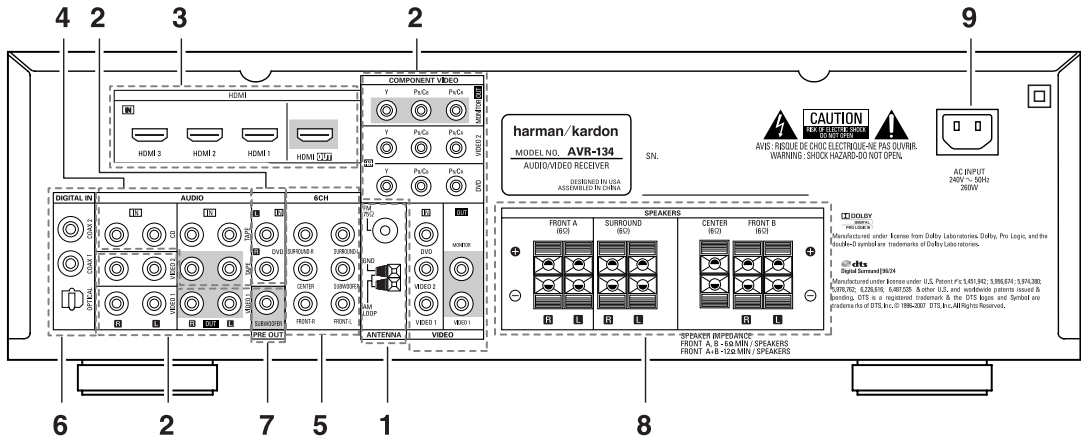

1. CONNECTING ANTENNAS

FM Indoor Antenna

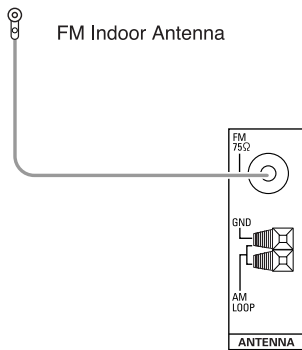

FM Outdoor Antenna

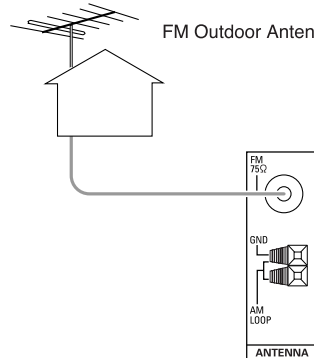

- Change the position of the FM indoor antenna until you get the best reception of your favorite FM stations.

- A 75Ω outdoor FM antenna may be used to further improve the reception. Disconnect the indoor antenna before replacing it with the outdoor one.

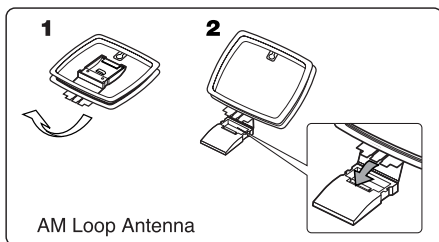

- Place the AM loop antenna as far as possible from the receiver, TV set, speaker cords and the AC cord and set it to a direction for the best reception.
- If the reception is poor with the AM loop antenna, an AM outdoor antenna can be used in place of the AM loop antenna.

AM Outdoor Antenna

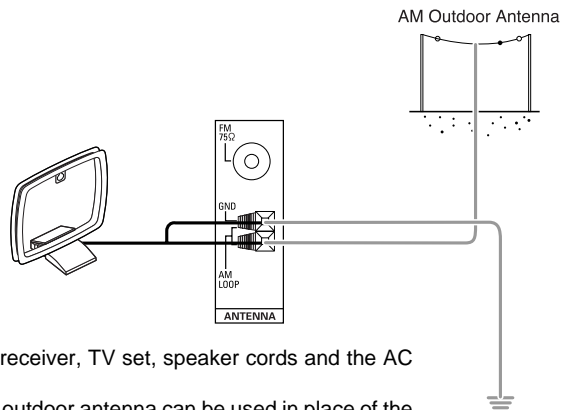

2. CONNECTING VIDEO COMPONENTS

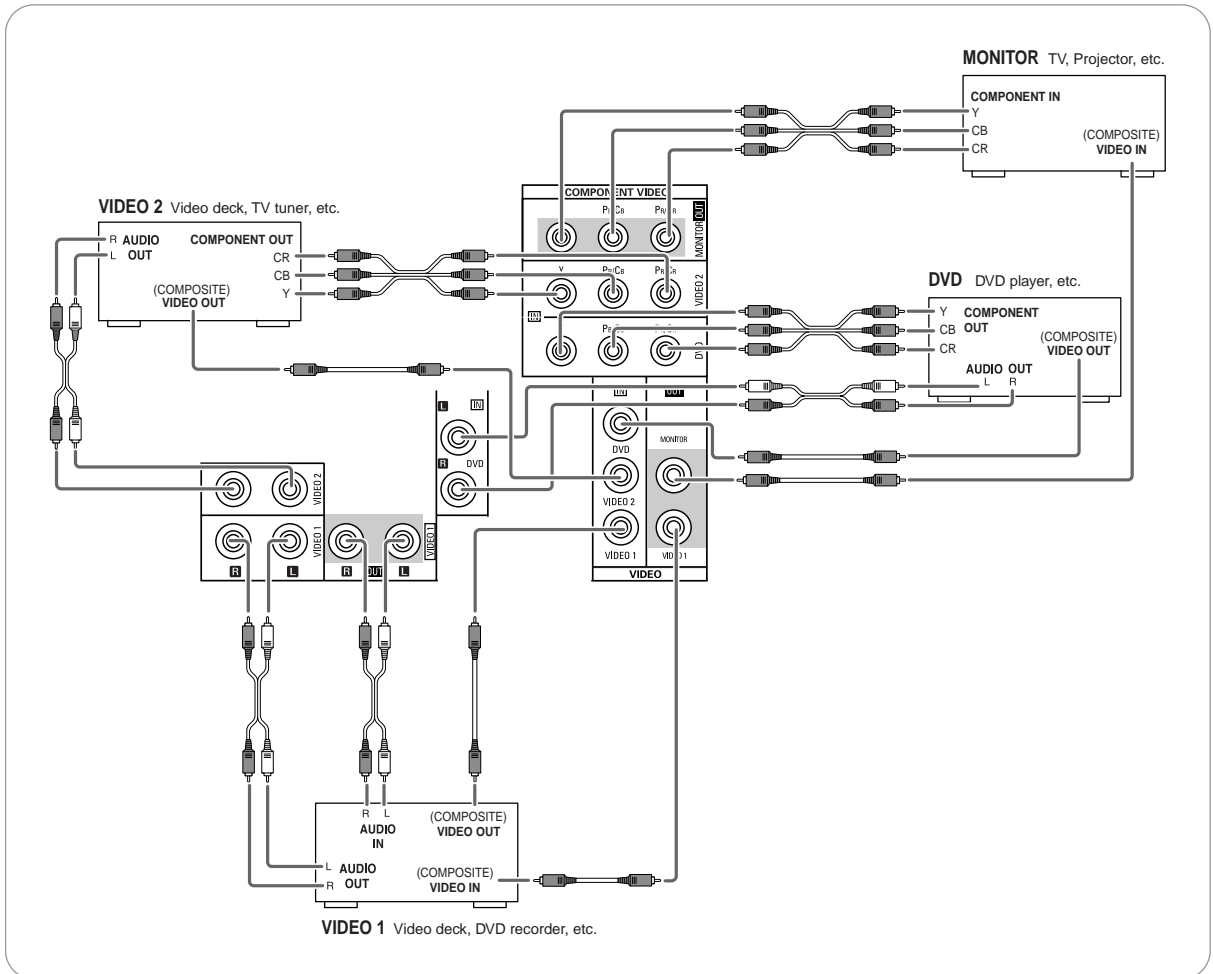

- The jacks of VIDEO 1 may also be connected to a DVD recorder or other video recording component. For details, refer to the operating instructions of the component to be connected.
- The jacks of VIDEO 2/DVD can also be connected to an additional video component such as a cable TV tuner, an LD player or satellite system.
- There are two types of video jacks (COMPONENT, (composite) VIDEO) for analog video connections. Connect them to the corresponding video jacks according to their capability.
- For your reference, the picture quality is as follows : "COMPONENT" > "(composite) VIDEO".
- When making COMPONENT VIDEO connections, connect "Y" to "Y", "PB/CB" to "Cb"(or "B-Y", "PB") and "PR/CR" to "Cr"(or "R-Y", "PR").

NOTE :

- When recording video program sources through VIDEO 1 OUT jacks or viewing video program sources through MONITOR OUT jack, you must use the same type of video jacks that you did connect to video playback components such as DVD player, LD player, etc.

3. HDMI (High Definition Multimedia Interface) CONNECTION

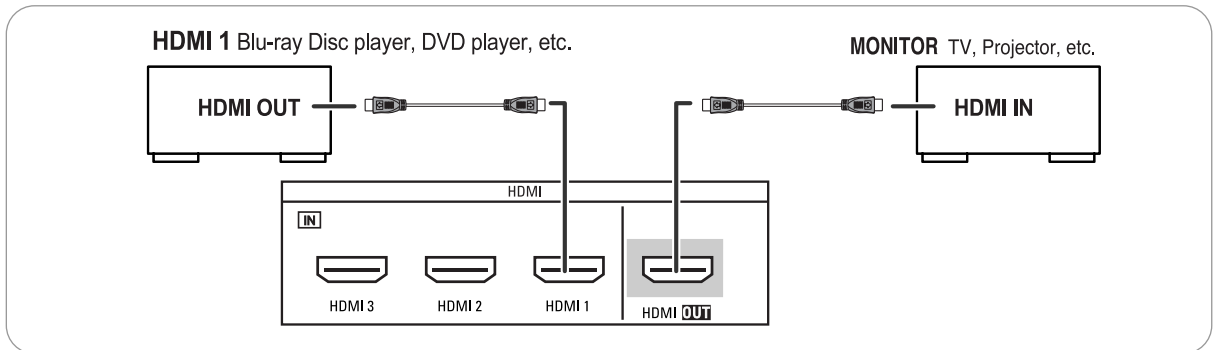

- HDMI 1 IN can be connected to a Blu-ray disc player or DVD player, etc.
- Connect HDMI 2/HDMI 3 IN to the video component in the same way.

■ HDMI connection

- You can connect the source component (Blu-ray disc player, DVD player, etc.) to the display component (TV, projector, etc.) through this receiver with using a commercially available HDMI cord.
- The HDMI connection can carry uncompressed digital video signals and digital audio signals.
- This receiver can output digital video and digital audio signals from the HDMI MONITOR OUT of this receiver without passing through any circuits as they were input into the HDMI IN, (meaning the audio signals which are input into the HDMI IN cannot be reproduced on this receiver). Therefore, to reproduce the audio signals on this receiver, you should make the digital audio connection additionally between the source component and this receiver. (For details, refer to "CONNECTING DIGITAL INs" on page 7.)
- This unit is HDMI Ver. 1.3 compatible.
- HDMI, the HDMI logo and High-Definition Multimedia Interface are trademarks or registered trademarks of HDMI licensing LLC.

■ Notes:

- Depending on the connected component, unreliable signal transfer may happen. (For details, refer to the operating instruction of your component.)
- For stable signal transfer, we recommend using HDMI cords that are a maximum of 5 meters in length.

4. CONNECTING AUDIO COMPONENTS

- The TAPE IN/OUT jacks can be connected to audio recording equipment such as a tape deck, an MD recorder, etc.
- The CD IN jacks can be connected to an additional audio components such as CD player, a tape deck, etc.

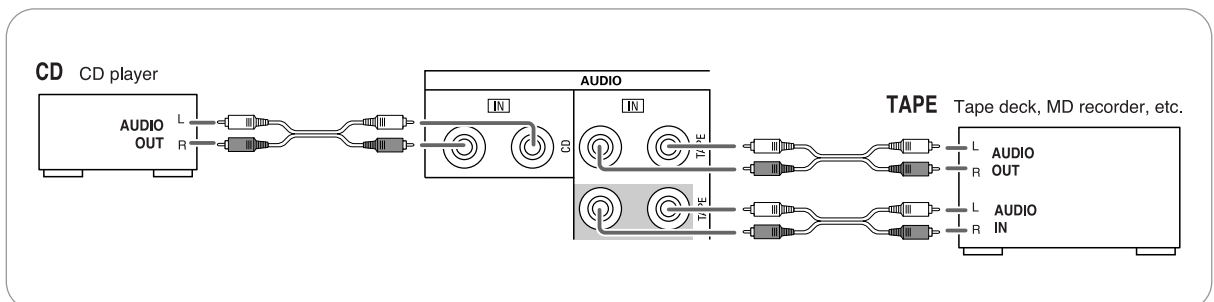

5. CONNECTING 6 CH DIRECT INPUT

- Use these jacks to connect the corresponding analog outputs of 6 CH decoder or DVD player with 6 CH output for Dolby Digital or DTS, etc. (For details, see the operating instructions of the component to be connected.)

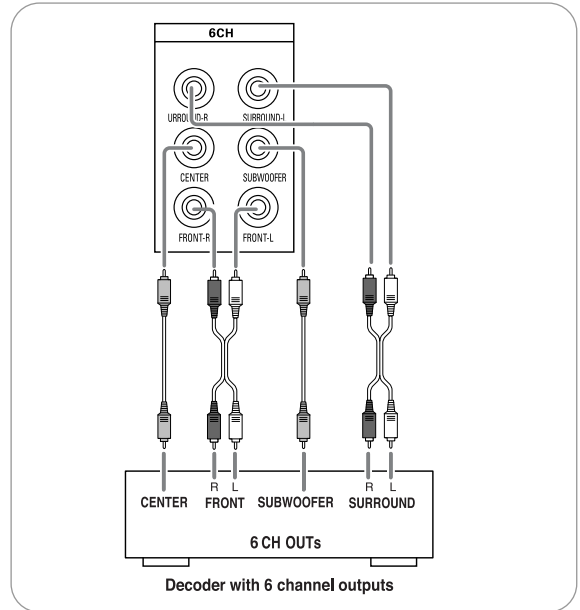

6. CONNECTING DIGITAL INs

- The OPTICAL and the COAXIAL DIGITAL OUTs of the components that are connected to CD, DVD, HDMI 1~ 3 and VIDEO 1 ~ VIDEO 2 of this unit can be connected to these DIGITAL INs.
- A digital input should be connected to the components such as a CD player, LD player, DVD player, etc. capable of outputting DTS Digital Surround, Dolby Digital or PCM format digital signals, etc.
- For details, refer to the operating instructions of the component connected.
- When making the COAXIAL DIGITAL connection, be sure to use a 75 Ω COAXIAL cord, not a conventional AUDIO cord.
- Not all the commercially available optical fiber cords can be used for the equipment. If there is an optical fiber cord which cannot be connected to your equipment, consult your dealer or nearest service organization.

NOTE : Be sure to make either a OPTICAL or a COAXIAL DIGITAL connection on each component. (You don't need to do both.)

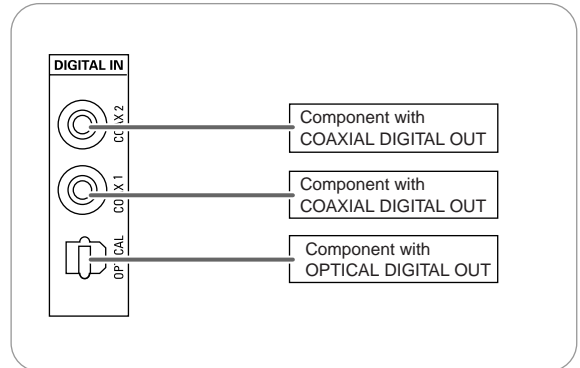

7. CONNECTING SUBWOOFER PRE OUT

- To emphasize the deep bass sounds, connect a powered subwoofer.

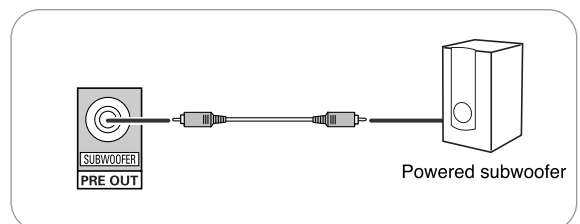

8. CONNECTING SPEAKERS

- You can connect two sets of front speakers and can select front A or/and B speakers according to your taste.
- Be sure to connect speakers firmly and correctly according to the channel(left and right) and the polarity(+ and -). If the connections are faulty, no sound will be heard from the speakers, and if the polarity of the speaker connection is incorrect, the sound will be unnatural and lack bass.
- For installing the speakers, refer to "Speaker placement" on page 9.
- After installing the speakers, first adjust the speaker settings according to your environment and speaker layout.(For details, refer to "SETTING THE SPEAKER SETUP" on page 37.)

Caution :

- For safe amplifier operation, in case of using either front A or front B speakers, use all the speakers with impedance of over 6 ohms. However, in case of using both front A and front B speakers, use only these speakers with impedance of over 12 ohms and other speakers with impedance of over 6 ohms.
- Do not let the bare speaker wires touch each other or any metal part of this unit. This could damage this unit and/or the speakers.

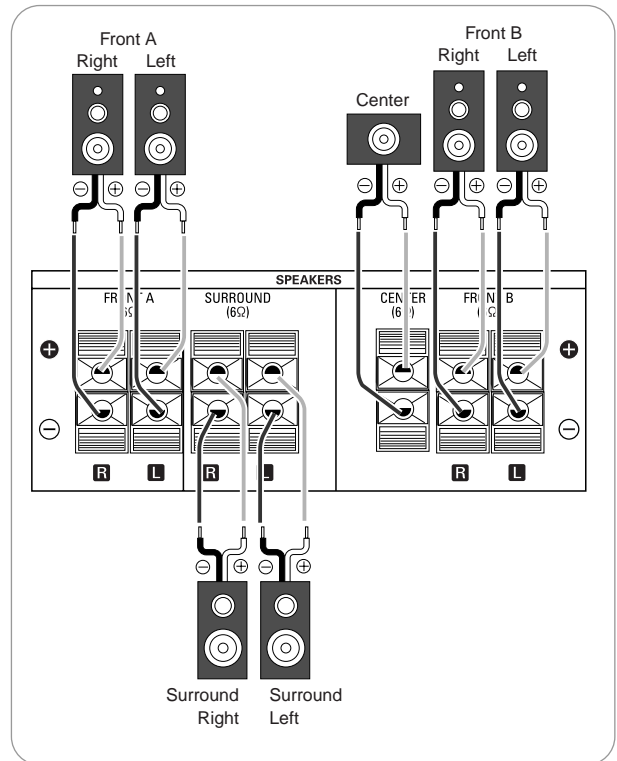

9. AC INPUT

- Plug the supplied AC cord into this AC INPUT and then into the wall AC outlet.

NOTE : Do not use an AC cord other than the one supplied with this unit. The AC cord supplied is designed for use with this unit and should not be used with any other device.

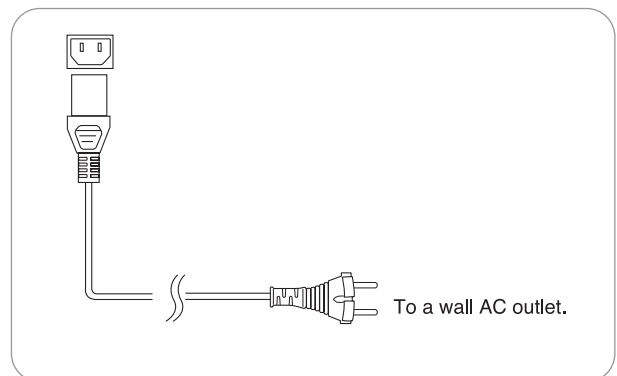

Speaker placement

Ideal speaker placement varies depending on the size of your room and the wall coverings, etc. The typical example of speaker placement and recommendations are as follows :

■ Front left and right speakers and center speaker

- Place the front speakers with their front surfaces as flush with TV or monitor screen as possible.
- Place the center speaker between the front left and right speakers and no further from the listening position than the front speakers.
- Place each speaker so that sound is aimed at the location of the listener's ears when at the main listening position.

■ Surround left and right speakers

- Place the surround speakers approximately 1 meter (40 inches) above the ear level of a seated listener to the direct left and right of them or slightly behind.

■ Subwoofer

- The subwoofer reproduces powerful deep bass sounds. Place a subwoofer anywhere along the front wall as desired.

■ Notes :

- When using a conventional TV, to avoid interference with the TV picture, use only magnetically shielded front left and right and center speakers.
- To obtain the best surround effects, the speakers except the subwoofer should be full range speakers.

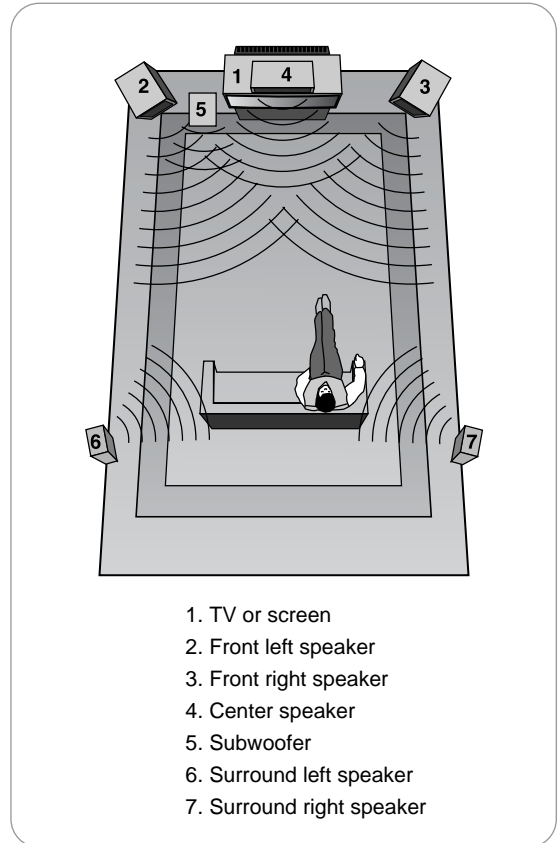

Front Panel Controls

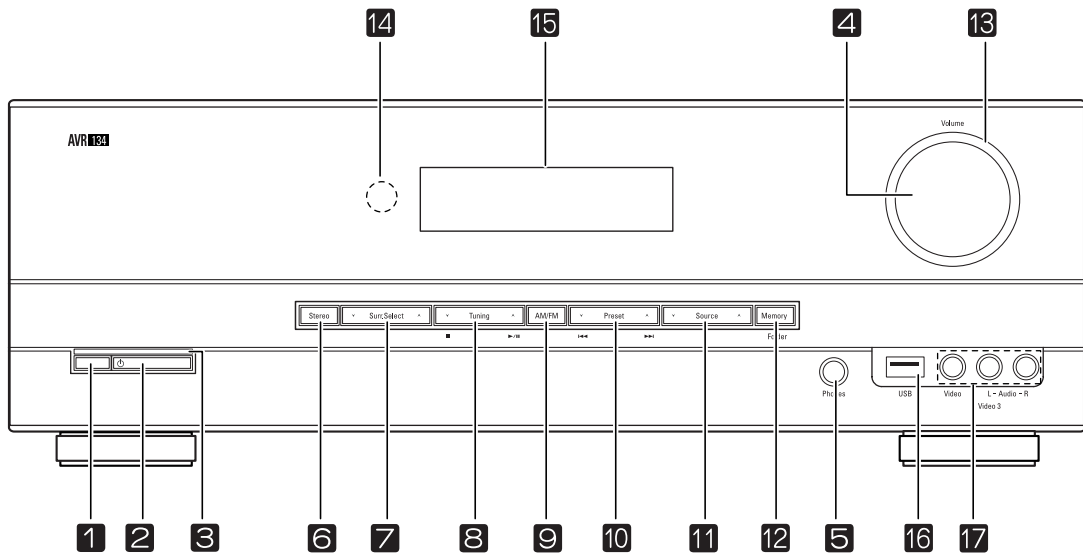

1 Main Power Switch: Press this button to apply power to the AVR. When the switch is pressed in, the unit is placed in a Standby mode, as indicated by the orange LED **3**. This button **MUST** be pressed in to operate the unit. To turn the unit off completely and prevent the use of the remote control, this switch should be pressed until it pops out from the front panel so that the word "OFF" may be read at the top of the switch.

NOTE: This switch is normally left in the "ON" position.

2 System Power Control: When the **Main Power Switch 1** is "ON", press this button to turn on the AVR; press it again to turn the unit off (to Standby). Note that the **Power Indicator 4** will turn blue when the unit is on.

3 Standby Indicator: This LED will be illuminated in orange when the unit is in the Standby mode to signal that the unit is ready to be turned on.

4 Power Indicator: This LED will be illuminated in blue when the unit is in operation.

5 Headphone Jack: This jack may be used to listen to the AVR's output through a pair of headphones. Be certain that the headphones have a standard 6.3 mm stereo phone plug.

6 Stereo Mode: Press this button to select a stereo playback mode.

7 Surround Select Up/Down: Press these buttons to select the desired surround mode. (See page 20 for more information.)

8 Tuning Up/Down: When the tuner is in use, these buttons will tune up or down through the selected frequency band. Pressing and holding down either of the buttons for more than 0.5 sec. will cause the tuner to seek the next station with acceptable signal strength for quality reception. Pressing these buttons briefly will tune stations in single-step increments/decrements. (See page 24 for more information.)

9 AM/FM Tuner select: Press this button to select the AVR's tuner as the listening choice. Pressing this button when the tuner is in use will select among FM Stereo, FM Mono and AM bands.

10 Preset Up/Down: When the tuner is in use, press these buttons to scroll through the stations programmed into the AVR's memory. (See page 25 for more information.)

NOTE: When the USB IN is in use, the Tuning Up/Down and the Preset Up/Down buttons on the front panel will serve as the USB In's transport functions. (See page 26 for more information.)

11 Input Source Selector: Press this button to change the input by scrolling through the list of input sources.

12 Memory: Press this button to enter a radio station into the AVR's preset memory.

13 Volume Control: Turn this knob clockwise to increase the volume, counterclockwise to decrease the volume. If the AVR is muted, adjusting volume control will automatically release the unit from the silenced condition.

14 Remote Sensor Window: The sensor behind this window receives infrared signals from the remote control. Aim the remote at this area and do not block or cover it.

15 Fluorescent Display: This display delivers messages and status indications to help you operate the unit.

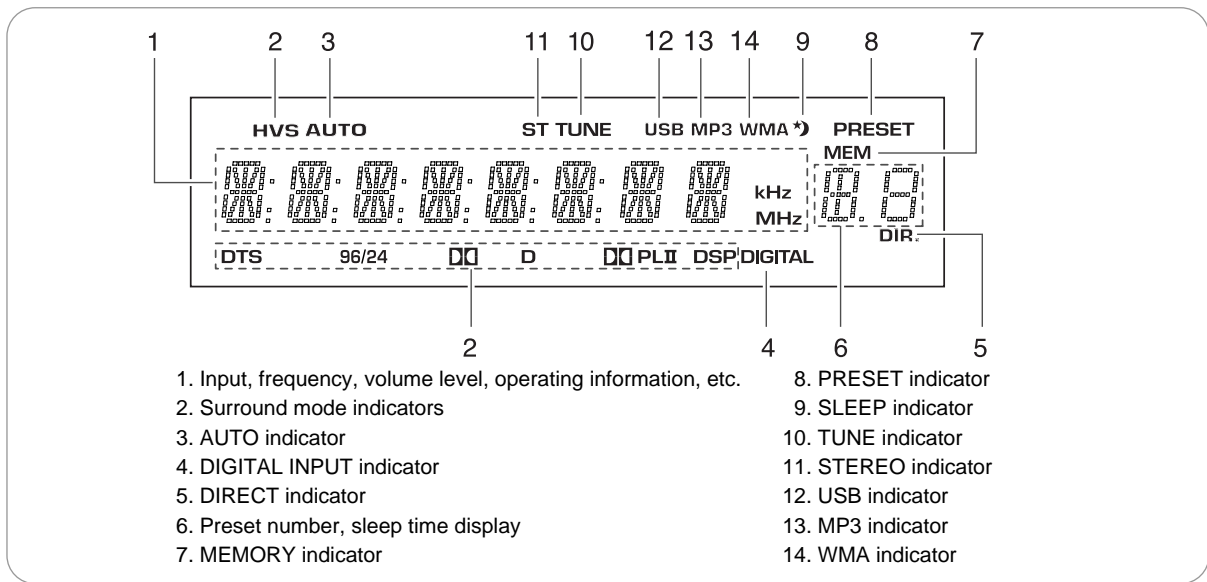

16 USB Connector: This connector can be connected to a USB mass storage device directly to enjoy MP3 or WMA files stored on it through this receiver. (For details on the operation of USB device, refer to “PLAYING MUSIC FILES(USB)” on page 26.)

NOTE: After USB playback, remove the USB device in the stop mode or the standby mode.

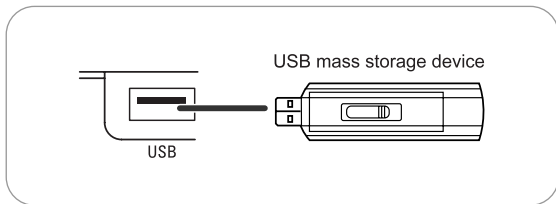

17 Video 3 Input Jacks: These audio/video jacks may be used for temporary connection to video games or portable audio/video products such as camcorders and portable audio player.

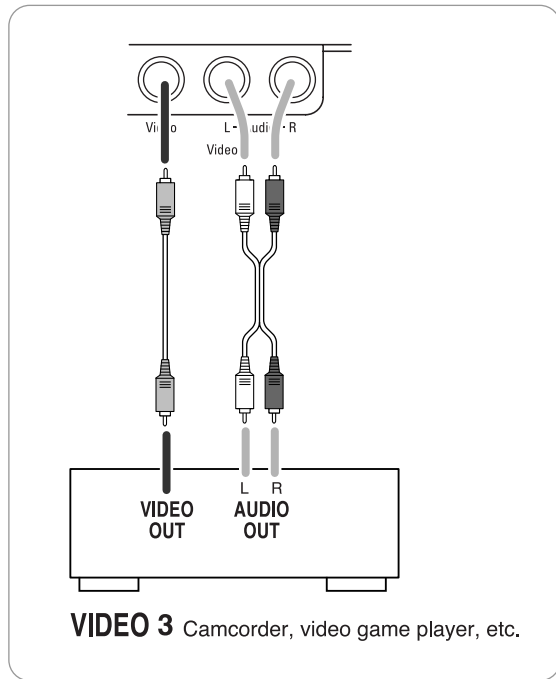

Remote Control Functions

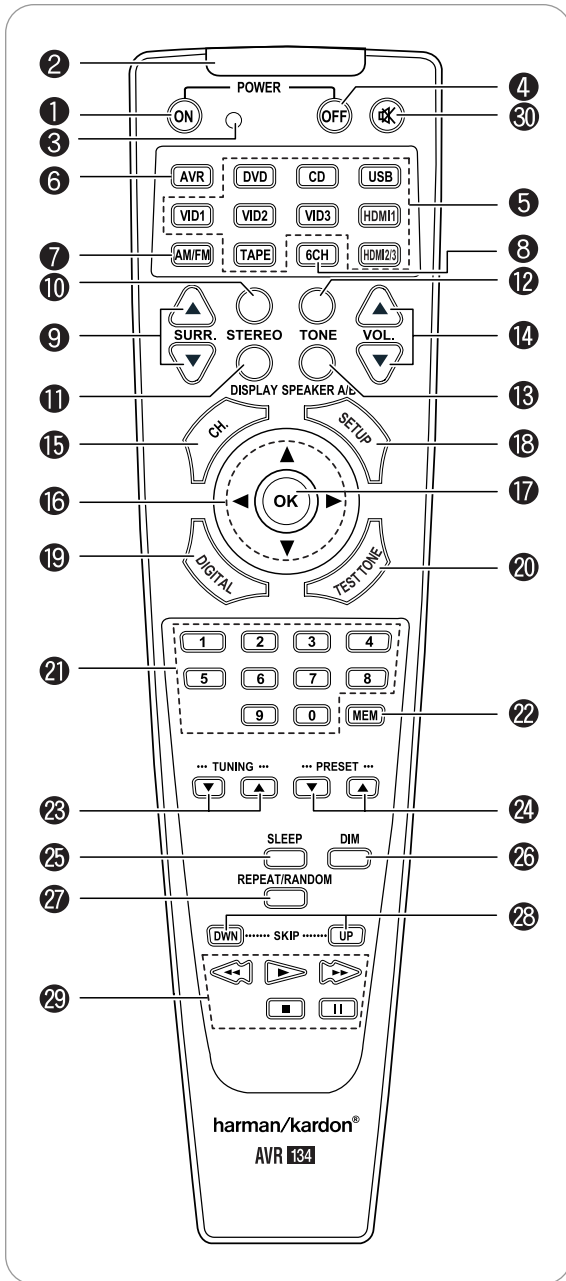

- 1 Power On button
- 2 IR Transmitter Window
- 3 LED
- 4 Power Off button
- 5 Input Selectors
- 6 AVR Selector
- 7 AM/FM Tuner Select
- 8 6-Channel Direct Input
- 9 Surround Select Up/Down
- 10 Stereo Mode button
- 11 Display button
- 12 Tone mode button
- 13 Speaker A/B Select button
- 14 Volume Up/Down
- 15 Channel Select button
- 16 Navigation(▲/▼/◀/▶) buttons
- 17 OK button
- 18 Setup button
- 19 Digital Input button
- 20 Test Tone button
- 21 Numeric keys
- 22 Memory button
- 23 Tuning Up/Down buttons
- 24 Preset Up/Down buttons
- 25 Sleep button
- 26 Dim button
- 27 Repeat/Random button
- 28 Skip Up/Down buttons
- 29 Transport controls
- 30 Mute button

NOTE: The function names shown here are each button's feature when used with the AVR. Most buttons have additional functions when used with other devices. See page 14 for a list of these functions.

IMPORTANT NOTE: The AVR's remote may be programmed to control Harman Kardon DVD players and USB mass storage devices, including the AVR. Before using the remote, it is important to remember to press one of AVR, DVD and USB selector buttons that corresponds to the unit you wish to operate.

- 1 Power On button:** Press this button to turn on the power to a device selected by pressing one of AVR and DVD Selector buttons.
- 2 IR Transmitter Window:** Point this window towards the device you wish to operate when pressing the button on the remote.
- 3 LED:** This lights in red when pressing a button on the remote.
- 4 Power Off button:** Press this button to switch off the AVR or Harman Kardon DVD player.
- 5 Input Selectors:** Pressing one of these buttons will perform three actions at the same time. First, if the AVR is not turned on, this will power up the unit. Next, it will select the source shown on the button as the input to the AVR. Finally, in case of pressing DVD Selector button, it will change the remote control so that it controls a Harman Kardon DVD player. After pressing DVD Selector button, you must press the AVR Selector button **6** again to operate the AVR's functions with the remote.
- 6 AVR Selector:** Pressing this button will switch the remote so that it will operate the AVR's functions. If the AVR is in the Standby mode, it will also turn the AVR on.
- 7 AM/FM Tuner Select:** Press this button to select the AVR's tuner as the listening choice. Pressing this button when the tuner is in use will select among FM Stereo, FM Mono and AM bands.
- 8 6-Channel Direct Input:** Press this button to select the component connected to the 6-Channel Direct Input on the rear panel as the audio. Note That when you wish to use the Six Channel Direct Input in conjunction with a video source, you must first select the video source by pressing one of the Input Selectors **5**. Then press this button to choose the 6-Channel Direct Input as the audio source.
- 9 Surround Select Up/Down:** Press these buttons to select the desired surround mode.(See page 20 for more information.)
- 10 Stereo Mode button:** Press this button to select a stereo playback mode.
- 11 Display button:** Press this button to check the current operation status such as surround mode, volume setting and input source.
- 12 Tone Mode button:** Pressing this button enables or disables the Bass and Treble tone controls.
- 13 Speaker A/B Select button:** Press this button to switch on Speaker A or/and B.
- 14 Volume Up/Down:** Press these buttons to raise or lower the system volume.
- 15 Channel Select button:** This button is used to start the process of setting the AVR's output levels with an external source. Once this button is pressed, use the **▲/▼** buttons **16** to select the channel being adjusted, then use the **◀/▶** buttons to change the level setting.(See page 22 for more information.)
- 16 Navigation(▲/▼/◀/▶) buttons:** These buttons are used to make selections within the system setup menu.
- 17 OK button:** Press this button to confirm your selection.
- 18 Setup button:** Press this button to begin the system setup process.
- 19 Digital Input button:** Press this button to assign one of the digital inputs to a source.(See page 17 for more information.)
- 20 Test Tone button:** Press this button to begin the sequence used to calibrate the AVR's output levels.(See page 21 for more information on calibrating the AVR.)
- 21 Numeric keys:** These buttons serve as a ten-button numeric keypad to enter tuner preset positions.
- 22 Memory button:** Press this button to enter a radio station into the AVR's preset memory.(See pages 24 and 25 for more information.)
- 23 Tuning Up/Down buttons:** When the tuner is in use, these buttons will seek up or down through the selected frequency band. Pressing and holding down either of the buttons for more than 0.5 sec. will cause the tuner to seek the next/previous station with acceptable signal strength for quality reception. Pressing these buttons briefly will tune stations in single-step increments/decrements.(See page 24 for more information.)
- 24 Preset Up/Down buttons:** When the tuner is in use, press these buttons to scroll through the stations programmed into the AVR's memory.
- 25 Sleep button:** Press this button to place the unit in the Sleep mode. After the time shown in the display, the AVR will automatically go into the Standby mode. Each press of the button changes the time until turn-off in the following order:
- 10 → 20 → 30 → → 90 → OFF

Unit: minutes
- 26 Dim button:** Press this button to activate or deactivate the Dimmer function, which reduces the brightness of the FI display, turns it off or turns it on completely.
- 27 Repeat/Random button:** When the USB In is in use, this button will start either repeat or random playback.(See page 28 for more information.)
- 28 Skip Up/Down buttons:** These buttons do not have a direct function with the AVR, but when used with a compatibly programmed DVD changer they will change the tracks on the disc currently being played in the changer.
- 29 Transport controls:** These buttons do not have any functions for the AVR, but they may be programmed for the forward/reverse play operation of a wide variety of DVD players and USB mass storage device.
- 30 Mute button:** Press this button to momentarily silence the AVR.

FUNCTION LIST

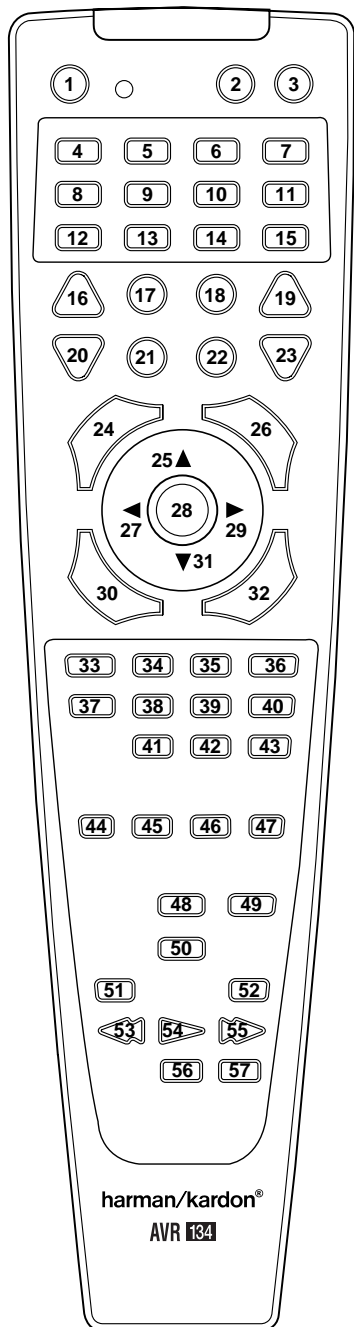

No.	Button name	AVR Function	DVD
1	Power On	Power On	Power On
2	Power Off	Power Off	Power Off
3	Mute	Mute	
4	AVR	AVR Select	
5	DVD	DVD Input Select	DVD Select
6	CD	CD Input Select	
7	USB	USB Input Select	
8	VID 1	Video 1 select	
9	VID 2	Video 2 select	
10	VID 3	Video 3 select	
11	HDMI 1	HDMI 1 Select	
12	AM/FM	Tuner Select	
13	TAPE	Tape Input Select	
14	6 CH Input Select	6 CH Input Select	
15	HDMI 2/3	HDMI 2/3 Select	
16	Surround Select Up	Surround Select Up	
17	Stereo Mode Select	Stereo Mode Select	
18	Tone Mode	Tone Mode	
19	Volume Up	Volume Up	
20	Surround Select Down	Surround Select Down	
21	Display	Display	
22	Speaker A/B Select	Speaker A/B Select	
23	Volume Down	Volume Down	
24	Channel Select	Channel Select	
25	▲	Up	
26	Setup	Setup	
27	◀	Adjust Down	
28	OK	OK	
29	▶	Adjust Up	
30	Digital Input	Digital Input	
31	▼	Down	
32	Test Tone	Test Tone	
33	1	1	
34	2	2	
35	3	3	
36	4	4	
37	5	5	
38	6	6	
39	7	7	
40	8	8	
41	9	9	
42	0	0	
43	Memory	Memory	
44	Tuning Down	Tuning Down	
45	Tuning Up	Tuning Up	
46	Preset Down	Preset Down	
47	Preset Up	Preset Up	
48	Sleep	Sleep	
49	Dim	Dim	
50	Repeat/Random	Repeat/Random(USB)	
51	Skip Down	Skip - (USB)	Skip -
52	Skip Up	Skip + (USB)	Skip +
53	Rewind		R.Search
54	Play	Play(USB)	Play
55	Fast Forward		F. Search
56	Stop	Stop(USB)	Stop
57	Pause	Pause(USB)	Pause

REMOTE CONTROL OPERATION RANGE

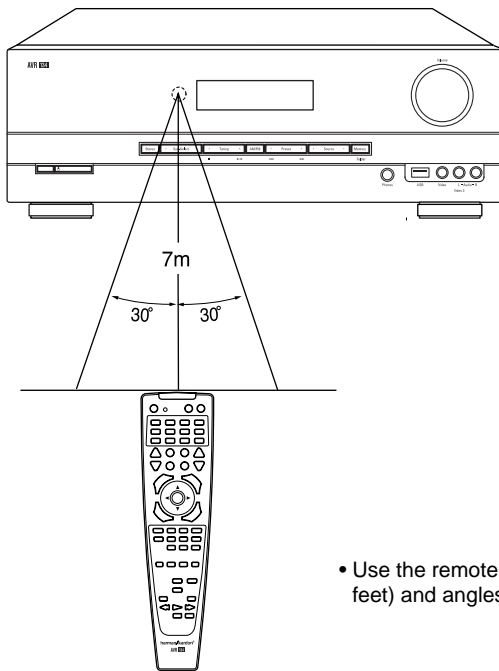

- Use the remote control unit within a range of about 7 meters (23 feet) and angles of up to 30 degrees aiming at the remote sensor.

LOADING BATTERIES

1. Remove the cover.

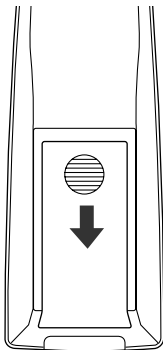

2. Load three batteries ("AAA" size, 1.5 V) matching the polarity.

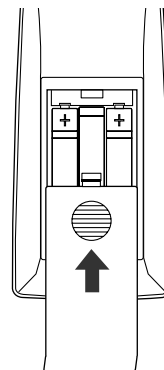

- Remove the batteries when they are not used for a long time.
- Do not use the rechargeable batteries (Ni-Cd type).
- Be sure to use alkaline batteries.

Operations

NOTES :

- Before operating this receiver with the supplied remote control, refer to "Remote Control Functions" on page 12.
- Before operating this receiver, first set this unit as desired for optimum performance, doing the system setup procedures. (For details, refer to "System Setup" on page 32.)
- After pressing the DVD button on the remote control, press the AVR button on the remote control to operate the AVR functions with it.

LISTENING TO A PROGRAM SOURCE

Before operation

- Enter the standby mode.
- The STANDBY indicator lights up orange. This means that the receiver is not disconnected from the AC mains and a small amount of current is retained to support the operation readiness.
- To switch the power off, push the MAIN POWER switch again.
- Then the power is cut off and the STANDBY indicator goes off.

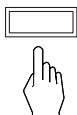

1. In the standby mode, turn the power on.

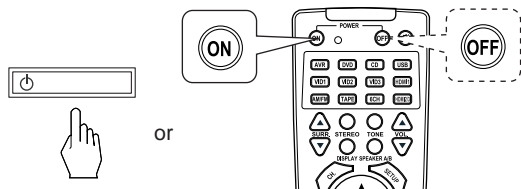

- Each time the SYSTEM POWER CONTROL button on the front panel is pressed, the receiver is turned on to enter the operating mode or off to enter the standby mode.
- On the remote control, press the POWER ON button to enter the operating mode or press the POWER OFF button to enter the standby mode.
- In the standby mode, if the INPUT SELECTOR button is pressed, the receiver is turned on automatically and the desired input is selected.

2. Switch the desired speakers on.

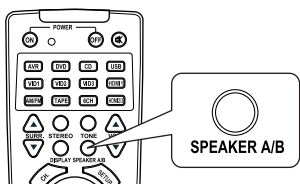

- Each time this button is pressed, the speakers are switched on or off as follows:
 → SPK : A → SPK : B → SPK : A+B → SPK : OFF →
- When using the headphone for private listening, switch off the A and B speakers.

3. Select the desired input source.

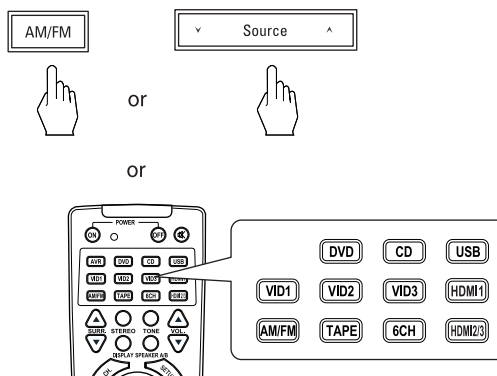

- Each time the "Source \wedge/\vee " buttons on the front panel is pressed, the input source changes as follows:
 → Tuner ↔ HDMI 1 ↔ HDMI 2 ↔ HDMI 3 ↔ TAPE ↔ 6 CH DIR (Frequency display) ↔ CD ↔ DVD ↔ VIDEO 3 ↔ VIDEO 2 ↔ VIDEO 1 ↔ USB IN ↔
- Each time the "HDMI 2/3" button on the remote control is pressed, the input source changes as follows:
 HDMI 2 ↔ HDMI 3
- Each time the "AM/FM" button is pressed, the band changes as follows:
 → FM ST → FM MONO → AM →
- When the 6CH DIRECT INPUT is selected, 6 separate analog signals from the component connected to this input pass through the volume circuits only and can be heard from your speakers.
- These analog signals can be heard only, not recorded.

When CD, DVD, HDMI 1~ 3, VIDEO 1~2 is selected as an input source

4. Select the digital or the analog input connected as desired.

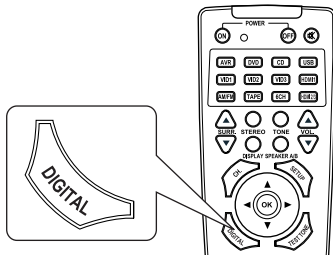

- Each time this button is pressed, the corresponding input is selected as follows:

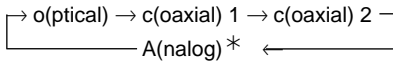

*: When HDMI 1~3 is selected, the analog input cannot be selected.

NOTES :

- When VIDEO 3, TUNER, USB IN, TAPE or 6CH DIRECT INPUT is selected as an input source, the analog input is selected automatically.
- When the selected digital input is not connected, the "DIGITAL" indicator flickers and the analog input may be automatically selected depending on the input source.
- The selected digital or analog input is automatically assigned to the corresponding input source on the INPUT setup menu. (For details, refer to "SETTING THE INPUT" on page 36.)
- The sound from the component connected to the selected digital input can be heard regardless of the selected input source.

5. Operate the selected component for playback.

- When playing back the program sources with surround sound, refer to "ENJOYING SURROUND SOUND" on page 20.

6. Adjust the (overall) volume.

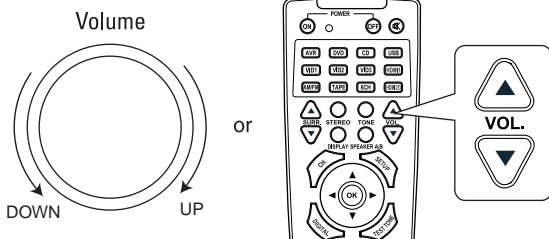

7. To mute the sound.

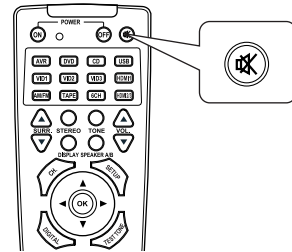

- "MUTE" will flicker.
- To resume the previous sound level, press it again.

8. To listen with the headphones.

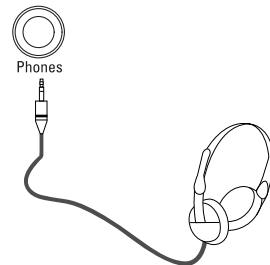

- Be sure to switch off all the speakers.
- When listening to a DTS or Dolby Digital program source, if the headphones are plugged in and the "SPEAKER A/B" button is set to off, it enters the 2CH DOWNMIX mode automatically. (For details, refer to "2 CH DOWNMIX mode" on page 20.)

NOTE: Be careful not to set the volume too high when using headphones.

Adjusting the tone (bass and treble)

9. Enter the tone mode.

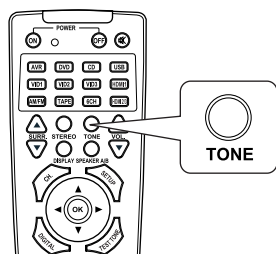

TONE: OFF

- The tone mode is displayed for several seconds.
- NOTE :** When the 6CH DIRECT INPUT is selected as an input source, you can neither select the tone mode nor adjust the tone.

■ When the TONE is set to ON to adjust the tone (bass and treble).

11. Press the ▲/▼ buttons to select the desired tone.

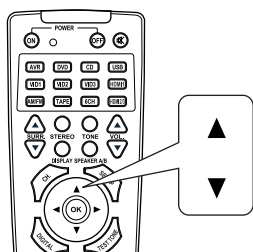

- Each time these buttons are pressed, the tone is selected as follows :

→ BASS ↔ TRBL (treble) ↔ TONE ON ←

10. Press the ◀/▶ buttons to select the desired tone mode.

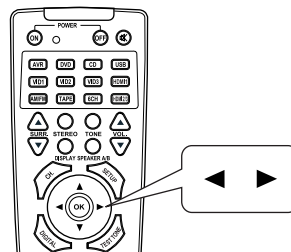

- Each time these buttons are pressed, the tone mode is selected as follows :

- OFF : To listen to a program source without the tone effect.
↓ ("DIR" indicator lights up.)
- ON : To adjust the tone to your taste.
("DIR" indicator goes off.)

12. Press the ◀/▶ buttons to adjust the selected tone as desired.

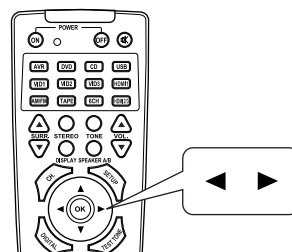

- The tone level can be adjusted within the range of -12 ~ +12 dB.
- In general, we recommend the bass and treble to be adjusted to 0 dB (flat level).
- Extreme settings at high volume may damage your speakers.
- To complete tone adjustment, repeat the above steps 11 and 12.
- If the tone display disappears, start from the step 9 again.

SURROUND SOUND

- This receiver incorporates a sophisticated Digital Signal Processor that allows you to create optimum sound quality and sound atmosphere in your personal Home Theater.

Surround modes

■ DTS Digital Surround

DTS Digital Surround(also called simply DTS) is a multi-channel digital signal format which can handle higher data rates. Discs bearing the DTS logo include the recording of up to 5.1 channels of digital signals, which can be generally thought to provide better sound quality due to the lower audio compression required.

It also provides wide dynamic range and separation, resulting in magnificent sound.

■ DTS 96/24

This is high resolution DTS with a 96 kHz sampling rate and 24 bit resolution, providing superior fidelity. Use it with DVDs bearing the DTS 96/24 logo.

Manufactured under license under U.S. Patent #'s: 5,451,942; 5,956,674; 5,974,380; 5,978,762; 6,226, 616; 6,487,535 & other U.S. and worldwide patents issued & pending. DTS and DTS Digital Surround are registered trademarks and the DTS logos , Symbol and DTS 96/24 are trademarks of DTS, Inc. © 1996-2008 DTS, Inc. All Rights Reserved.

■ Dolby Digital

Dolby Digital is the multi-channel digital signal format developed by Dolby Laboratories. Discs bearing the Dolby Digital logo includes the recording of up to 5. 1 channels of digital signals, which can reproduce much better sound quality, spatial expansion and dynamic range characteristics than the previous Dolby Surround effect.

■ Dolby Pro Logic II surround

This mode applies conventional 2- channel signals such as digital PCM or analog stereo signals as well as Dolby Surround signals, etc. to surround processing to offer improvements over conventional Dolby Pro Logic circuits. Dolby Pro Logic II surround includes 3 modes as follows:

• Dolby Pro Logic II MOVIE

When enjoying movies, this mode allows you to further enhance the cinematic quality by adding processing that emphasizes the sounds of the action special effects.

• Dolby Pro Logic II MUSIC

When listening to music, this mode allows you to further enhance the sound quality by adding processing that emphasizes the musical effects.

• Dolby Pro Logic II Emulation

This mode expands any 2-channel sources(, including Dolby Surround sources) for 4 channel(front left, center, front right and surround) playback.

The surround channel is monaural, but is played through two surround speakers.

Dolby, Pro Logic, and the double-D symbol are registered trademarks of Dolby Laboratories.

- The following modes apply conventional 2-channel signals such as digital PCM or analog stereo signals to high performance Digital Signal Processor to recreate sound fields artificially.

■ Virtual Surround 2 Speaker

This mode creates a virtual surround sound field using as few as two front speakers, allowing you to experience listening from 5.1 channel speakers.

This mode is effective not only for 5.1 channel sources but also for 2 channel sources.

■ Virtual Surround 3 Speaker

This mode creates a virtual surround sound field using two front and one center speakers, allowing you to experience listening from 5.1 channel speakers. This mode is effective only for 5.1 channel sources.

■ Theater

This mode provides the effect of being in a movie theater when watching a movie source.

■ Hall

This mode provides the ambience of a concert hall for classical music sources such as orchestral, chamber music, or an instrumental solo.

■ Stadium

This mode provides the expansive sound field to achieve the true stadium effect when watching baseball or soccer games.

■ Club

This mode provides the sound field of a house with a low ceiling and hard walls for jazz music.

■ Arena

This mode provides a dynamic and broad sound space to heighten the overall impact of the sound track.

■ 5CH Stereo

This mode is for enjoying stereo sound from all speakers.

■ Virtual Surround Headphone

This mode simulates 5.1 channel surround sound, which allows you to enjoy 5.1 channel surround sound through 2 channel headphone, just like listening from 5.1 channel speakers. This mode may be used not only with 5.1 channel sources but also with 2 channel sources.

- When the 6CH DIRECT INPUT is selected as an input source, the surround modes cannot be selected.

ENJOYING SURROUND SOUND

NOTES:

- Before surround playback, first perform the speaker setup procedure, etc. on the SETUP menu for optimum performance. (For details, refer to "SETTING THE SPEAKER SETUP" on page 37.)
- When the 6CH DIRECT INPUT is selected as an input source, the surround modes cannot be selected.
- Select the desired surround mode.

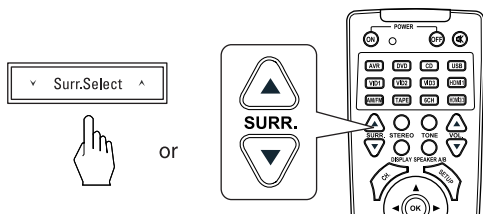

- Each time the SURROUND SELECT UP / DOWN buttons are pressed, the surround mode changes depending on the input signal format as follows :

Signal format being input	Selectable surround mode
Dolby Digital 5.1 channel sources	DOLBY DIGITAL, VS 2 SPK, VS 3 SPK
Dolby Digital 2 channel sources,	DOLBY PLII MOVIE, DOLBY PLII MUSIC, DOLBY PLII EMULATION, VS 2 SPK
DTS sources, DTS 96/24 sources	Corresponding DTS mode, VS 2 SPK, VS 3 SPK
PCM (2channel) sources, Analog stereo sources	DOLBY PLII MOVIE, DOLBY PLII MUSIC, DOLBY PLII EMULATION, VS 2 SPK, THEATER, HALL, STADIUM, CLUB, ARENA, 5CH STEREO
96 kHz PCM(2 channel) sources Music files from USB	DOLBY PLII MOVIE, DOLBY PLII MUSIC, DOLBY PLII EMULATION

■ To cancel the surround mode for stereo playback

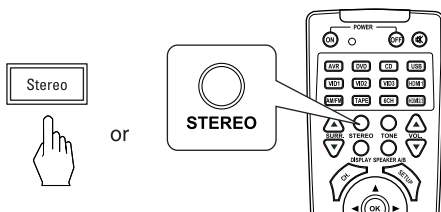

- Depending on the signal format which is being input, either the STEREO mode or the 2CH DOWNMIX mode is selected.
- To cancel either the STEREO mode or the 2CH DOWNMIX mode, select surround mode with the SURROUND SELECT UP/ DOWN buttons.

■ 2CH DOWNMIX mode

- This mode allows the multi-channel signals encoded in DTS or Dolby Digital format to be mixed down into 2 front channels and to be reproduced through only two front speakers or through headphones.
- When all the speakers are switched off to listen with headphones while playing the multi-channel digital signals from DTS or Dolby Digital sources, it can enter the 2 CH DOWNMIX mode.

Listening in Virtual Surround Headphone mode

- The Virtual Surround Headphone mode simulates 5.1 channel surround sound, which allows you to enjoy 5.1 channel surround sound through 2 channel headphones, just like listening from 5.1 channel speakers.

NOTES :

- Virtual Surround Headphone mode can be selected only when all the speakers are switched off.
- When listening to music files from the USB mass storage device, the Virtual Surround Headphone mode cannot be selected.
- Select the Virtual Surround Headphone mode.

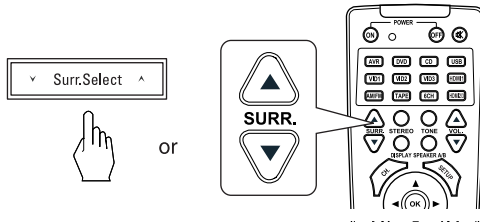

- Then "VS HP" is displayed and the Virtual Surround Headphone mode is selected.
- To cancel the Virtual Surround Headphone mode, press the STEREO MODE button.

Adjusting each channel level with test tone

- The volume level of each channel can be adjusted easily with the test tone function.

1. Enter the test tone mode.

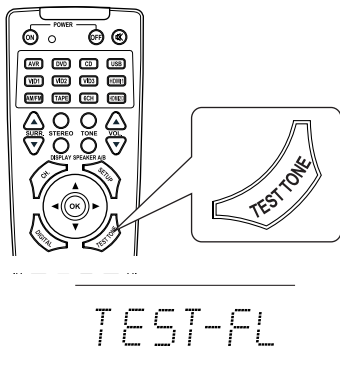

- The test tone mode is displayed and will be heard from the speaker of each channel for 2 seconds as follows:

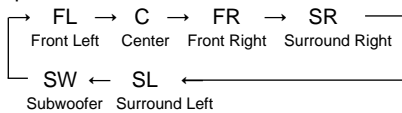

- When the speaker setting is "N (None or No)", the test tone of the corresponding channel is not available.

NOTE:

- ※ The test tone function does not work as expected if :
 - All the speakers are switched off.
 - USB IN or 6CH DIRECT INPUT is selected as an input source.
 - If the unit is in the STEREO or the 2CH DOWNMIX mode.

2. For each channel, adjust the level as desired until the sound level of each speaker is heard to be equally loud.

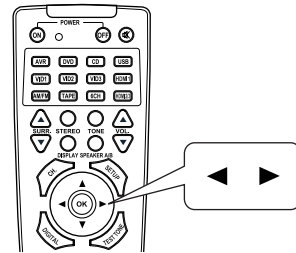

- You can select the desired channel with pressing the ▲/▼ buttons.

3. Cancel the test tone function.

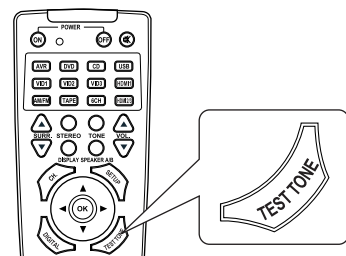

Adjusting the current channel level

- After adjusting each channel level with test tone, adjust the channel levels either according to the program sources or to suit your tastes.
- You can adjust the current channel levels as desired. These adjusted levels are just memorized into user's memory ("CAL"), not into preset memory("REF 1", "REF 2").

1. Press the CHANNEL SELECT button.

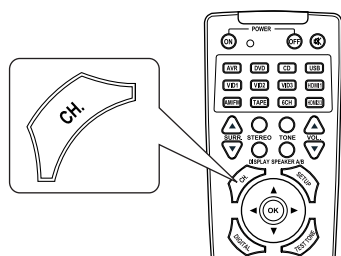

MODE:REF 1

- Then the memory mode ("REF1", etc.) is displayed for several seconds.
- When the memory mode or channel level disappears, press this button again.

2. Select the desired channel.

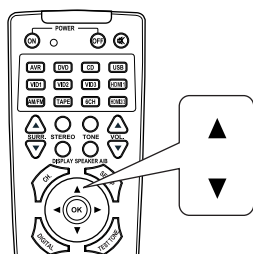

- Each time these buttons are pressed, the corresponding channel is selected as follows:
 - ↳ REF 1, 2(or CAL) ↔ FL ↔ C ↔ FR ↳
 - ↳ <DTS or DD> ↔ SW ↔ SL ↔ SR ↳
- < >: Only when the digital signals from Dolby Digital or DTS program sources that include LFE signal are input, LFE level is displayed.
- Depending on the speaker settings ("N (None or No)") and surround mode, etc., some channels cannot be selected.
- When all the speakers are switched off, only the Front Left and Front Right channels can be selected.

3. Adjust the level of the selected channel as desired.

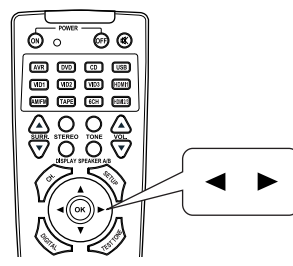

- The LFE level can be adjusted within the range of -10~0 dB and other channel levels within the range of -15 ~ +15 dB.
- In general, we recommend the LFE level to be adjusted to 0 dB.(However, the recommended LFE level for some early DTS software is -10 dB.) If the recommended levels seem too high, lower the setting as necessary.

4. Repeat the above steps 2 and 3 to adjust each channel level.

Memorizing the adjusted channel levels

- You can memorize the adjusted channel levels into preset memory("REF 1", "REF 2") and recall the memorized whenever you want.

- After performing the steps 1 ~ 4 in "Adjusting the current channel level" procedure on page 22, press the OK button.

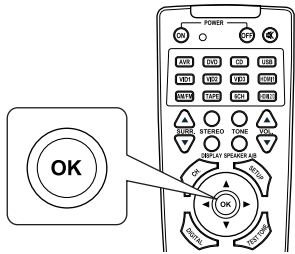

MODE REF 1

- Then "1" of "REF 1" indication flickers for several seconds.

- Select the desired one of REF 1 and REF 2.

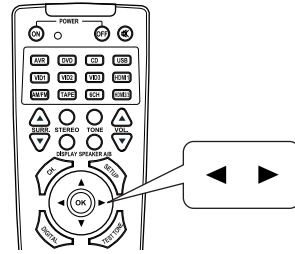

- If the preset memory disappears, perform the above step 1 again.

- Confirm your selection.

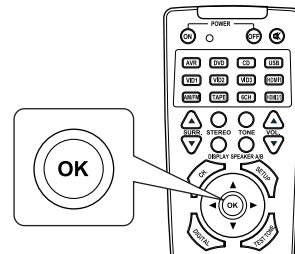

- The adjusted channel levels have now been memorized into the selected memory.

Recalling the memorized channel levels

- Press the CHANNEL SELECT button.

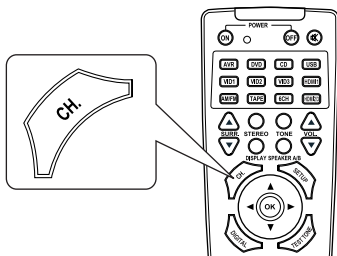

- "CAL " (or "REF 1", etc.) is displayed for several seconds.
- If the channel level mode display disappears, press this button again.

- Select the desired one of REF 1 and REF 2.

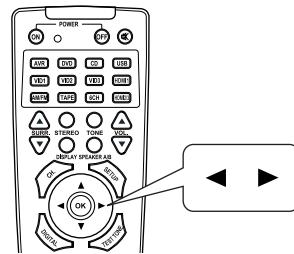

- The channel levels memorized into the selected preset memory are recalled.

LISTENING TO RADIO BROADCASTS

Auto tuning

1. Select the desired band.

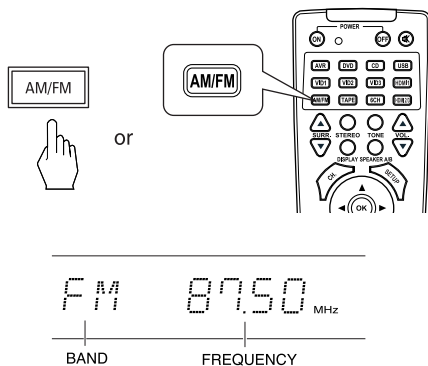

• Each time this button is pressed, the band changes as follows ;

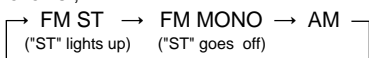

• When FM stereo broadcasts are poor because of weak broadcast signals, select FM mono mode to reduce noise, causing FM broadcasts to be reproduced in monaural sound.

Manual tuning

- Manual tuning is useful when you already know the frequency of the desired station.
- After selecting the desired band, press the TUNING UP/DOWN buttons repeatedly until the right frequency has been reached.

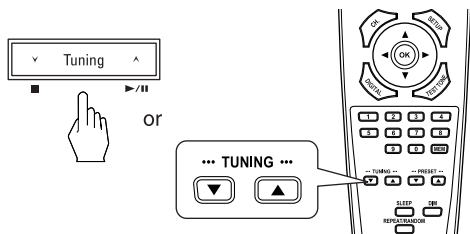

2. Press the TUNING UP/DOWN buttons for more than 0.5 second.

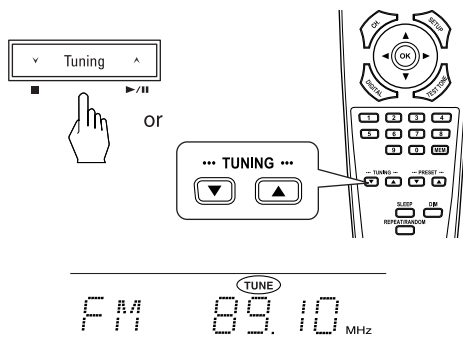

- The tuner will now search until a station of sufficient strength has been found. The display shows the tuned frequency and "TUNE".
- If the station found is not the desired one, simply repeat this operation.
- Weak stations are skipped during auto tuning.

Auto presetting

- Auto presetting function automatically searches for FM stations only and store them in the memory.
- While listening to FM radio broadcasts, press and hold down the MEMORY button for more than 2 seconds.

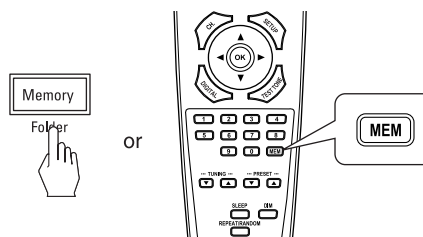

- Then "AUTO MEM" flickers and the receiver starts auto presetting.
- Up to 30 FM stations can be stored.

NOTES:

- Weak FM stations are not memoried.
- To memorize AM stations or weak stations, perform "Manual presetting" procedure with using "Manual tuning" operation.

Manual presetting

- You can store up to 30 preferred stations in the memory.

1. Tune in the desired station with auto or manual tuning.

2. Press the MEMORY button.

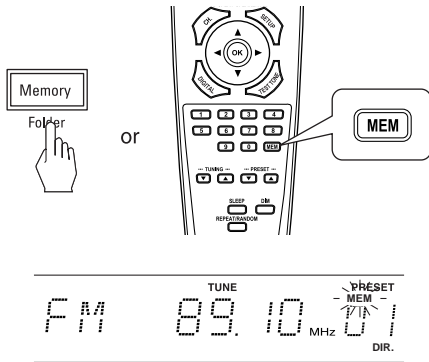

- "MEM" is flickering for several seconds.

4. Repeat the above steps 1 to 3 to memorize other stations.

■ MEMORY BACKUP FUNCTION

The following items, set before the receiver is turned off, are memorized.

- INPUT SELECTOR settings
- Surround mode settings
- Preset stations, etc.

Tuning to preset stations

- After selecting the tuner as an input source, select the desired preset number.

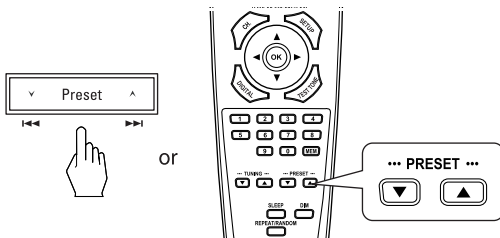

3. Select the desired preset number (1-30) and press the MEMORY button.

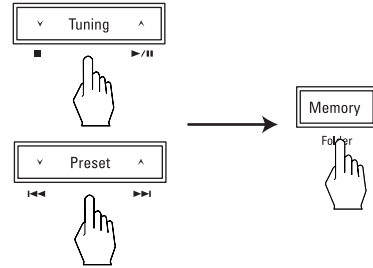

- When using the NUMERIC buttons on the remote control.

Examples) For "3" :

For "15" : within 2 seconds →

For "30" : within 2 seconds →

- The station has now been stored in the memory.
- When using the NUMERIC buttons, the station is stored automatically without pressing the MEMORY button.
- A stored frequency is erased from the memory by storing another frequency in its place.
- If "MEM" goes off, start again from the above step 2.

PLAYING MUSIC FILES(USB)

- When connecting a USB mass storage device to this unit, you can enjoy MP3 or WMA files stored on it through this receiver.
- A total of 65536 folders and files can be supported.
Therefore, it is not possible to play folders and files that exceed the maximum limitations.

■ MP3

- MP3 files must have a “.mp3” or “.MP3” file name extension.
- It is recommended that you record your material at a 44.1kHz sampling rate, using the 96~320 kbps data transfer rate.
- Fixed bit-rate files are recommended. Variable bit-rate(VBR) files are playable, but playing time may be displayed incorrectly.

■ WMA

- WMA files must have a “.wma” or “.WMA” file name extension.
- It is recommended that you record your material at a bit rate of 64 kbps or higher.
- This unit cannot play files recorded with a bit rate of 80 and 256 kbps.

■ Compatible USB mass storage device:

- USB flash memory(USB 2.0 or USB 1.1)
- USB flash players(USB 2.0 or USB 1.1)
- Memory cards(requires an additional card reader to work with this receiver)

■ Supported formats:

- USB or memory file format FAT 16 or FAT 32.

NOTES:

- It is not possible to connect this unit to a PC for USB playback.
- We cannot guarantee compatibility with all USB mass storage devices and assumes no responsibility for any loss of data that may occur when connected to this unit.
- During USB playback, do not remove the USB device. Should this happen, it may be result in malfunction or cause damage to this unit and/or the USB device. To prevent it, after USB playback, remove the USB device in the stop mode or the standby mode.

1. Select the USB IN as an input source.

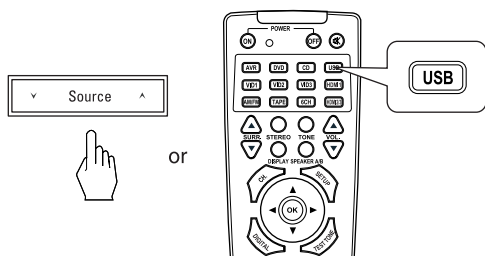

2. Plug the USB device into the USB connector on the front panel.

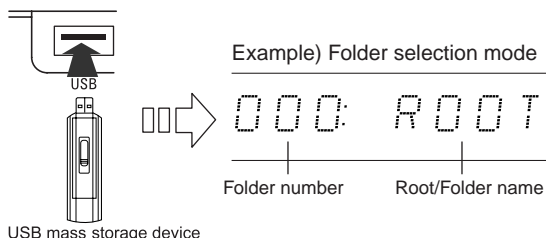

NOTE: Depending on the file types, etc. it may take time to read the files stored on the USB device.

3. In the stop mode, select the desired selection mode.

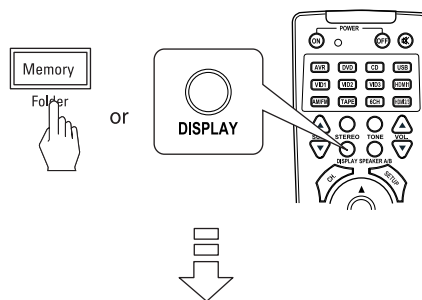

Example) File selection mode

012:TOTAL

Total number of files

- Each time this button is pressed, the selection mode changes as follows :
 - Folder selection mode : To select the desired folder ("000 : ROOT", etc.)
 - File selection mode : To select the desired file in the selected folder. ("012 : TOTAL", etc.)

NOTE : When it is in the stop mode, you can select the selection mode.

4. Select the desired folder or file.

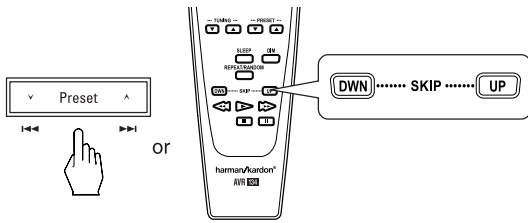

- Each time the button is pressed, the folder or the file is selected according to the selection mode.

5. Start playback.

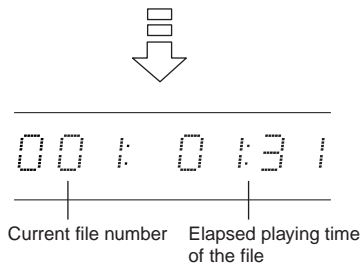
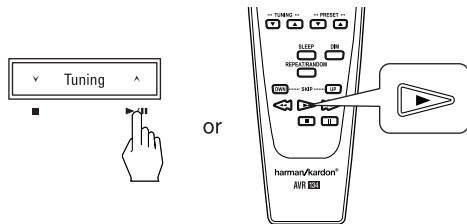

NOTE:

- When there are no MP3 or WMA files, playback will not start.
- Due to display limitations, even if the playing time exceeds 99 min. 59 sec., this receiver cannot display more than 99 min. 59 sec..
- Even if the file number exceeds 999, this receiver cannot display more than 999.

6. To interrupt playback temporarily.

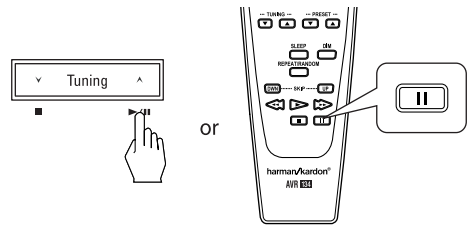

- To resume playback, press the PLAY button or the "Tuning ^" button.

7. To stop playback.

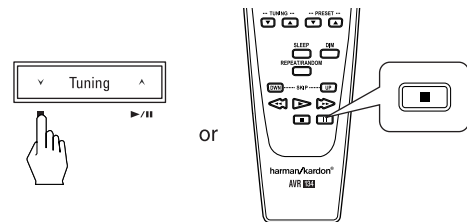

- Then playback of a file is stopped and the receiver memorizes the file where the STOP button or the "Tuning v" button is pressed (Resume function). If the PLAY button or the "Tuning ^" button is pressed, playback will resume from the beginning of the memorized file.
- When the STOP button or the "Tuning v" button is pressed while operating the resume function, it enters the STOP mode. If the PLAY button or the "Tuning ^" button is pressed, playback will start from the first file.

Skipping ahead or back during playback

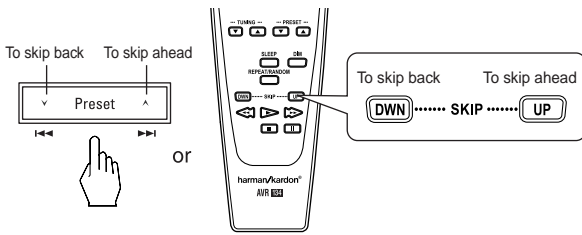

- Each time the button is pressed, a file is skipped.
- You can select a file directly with pressing the NUMERIC buttons.

Example) For "3" : **3**
 For "15" : **1** → within 2 seconds → **5**
 For "247" : **2** → within 2 seconds → **4** → within 2 seconds → **7**

NOTE : You can select a file in the current folder only.

Repeat/Random playback

- You can play a file, all the files repeatedly or files repeatedly in random order.
- During playback, press the REPEAT/RANDOM button to select the desired playback mode.

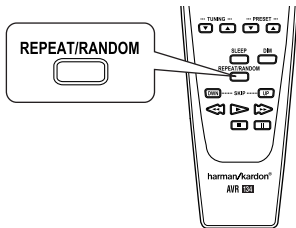

- Each time this button is pressed, the playback mode is selected as follows:
 - "RPT(Repeat) ONE" : To play a file repeatedly ("1" lights up)
 - ↓
 - "RPT(Repeat) FLD(Folder)" : To play files repeatedly in the current folder ("F" lights up)
 - ↓
 - "F(Folder)-RANDOM" : To play files repeatedly in random order in the current folder ("□ F" lights up)
 - ↓
 - "RPT ALL" : To play all files repeatedly ("A" lights up)
 - ↓
 - "RPT OFF" : Normal playback

Displaying file information during playback

- You can display file information such as file name, title name, artist name and file number/elapsed playing time.

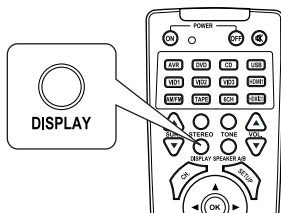

- Each time this button is pressed, the display mode changes as follows:

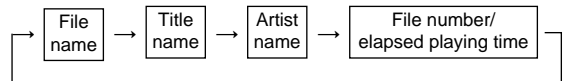

NOTES :

- If the name information is not available, it will not be displayed.
- Characters except "A~Z", "0~9", "-" may be not displayed.

RECORDING

- The analog signals from the 6CH DIRECT INPUT as well as the digital signals from the coaxial, optical digital input, HDMI INs or USB IN can be heard but cannot be recorded.
- When recording the analog signals from CD, DVD, VIDEO 1~2, be sure to select the analog input. (For details, refer to "When CD, DVD, HDMI 1~3, VIDEO 1~2 is selected as an input source" on page 17.)
- The volume and tone (bass, treble) settings have no effect on the recording signals.

Recording to TAPE

1. Select the desired input as a recording source (except TAPE and 6CH DIRECT INPUT).

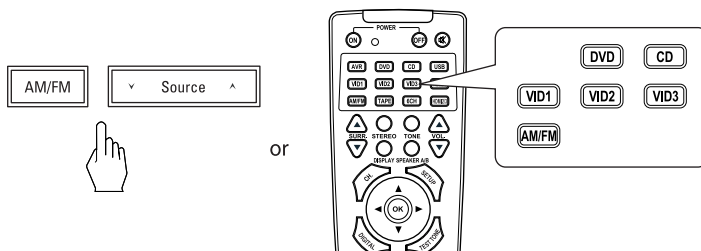

2. Start recording on the TAPE.

3. Start play on the desired input.

Dubbing from video components onto VIDEO 1

1. Select the desired of DVD and VIDEO 2 ~ 3 as a recording source (not VIDEO 1).

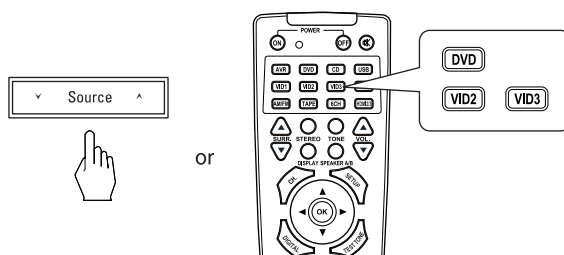

2. Start recording on the VIDEO 1.

3. Start play on the desired input.

- The audio and video signals from the desired input will be dubbed onto the VIDEO 1 and you can enjoy them on the TV set and from the speakers.

Dubbing the audio and video signals separately onto VIDEO 1

Example) When dubbing the VIDEO 2 video signal and the CD audio signal separately onto VIDEO 1.

NOTE: When selecting a video recording source and an audio recording source respectively, press the input selector buttons on the remote control, not the “Source \wedge/\vee ” buttons on the front panel.

1. Select VIDEO 2 as a video recording source.

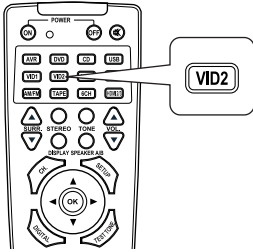

2. Select CD as an audio recording source.

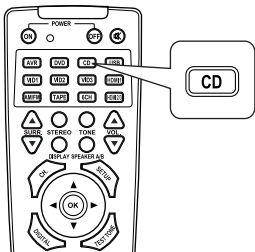

3. Start recording on the VIDEO 1.

4. Start play on the VIDEO 2 and the CD respectively.

- The audio signal from the CD and the video signal from the VIDEO 2 will be dubbed and you can enjoy them on the TV set and from the speakers.

NOTE : Be sure to observe the order of the above steps 1 and 2.

OTHER FUNCTIONS

Operating the sleep timer

- The sleep timer allows the system to continue to operate for a specified period of time before automatically shutting off.
- To set the receiver to automatically turn off after the specified period of time.

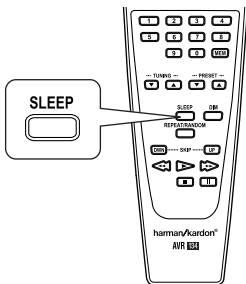

- Each time this button is pressed, the sleep time changes as follows:

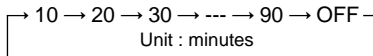

- While operating the sleep timer, " * " lights up.
- When the sleep time is selected, the fluorescent display is dimly lit.

Adjusting the brightness of the fluorescent display

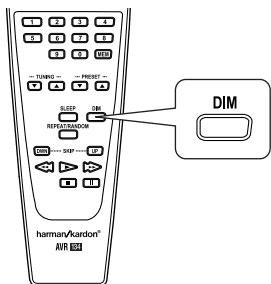

- Each time this button is pressed, the brightness of the fluorescent display changes as follows:

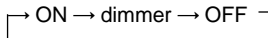

- In the display OFF mode, pressing any button will restore the display ON mode.

Displaying the operation status

During playback,

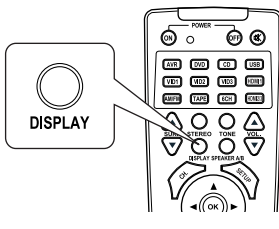

- Each time this button is pressed, the display mode changes as follows:

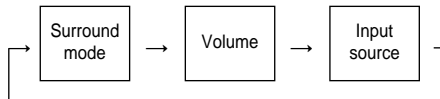

- When the 6CH DIRECT INPUT is selected as an input source, the surround mode is not displayed.
- When the USB IN is selected as an input source, for details on the file information, see "Displaying file information during playback" on page 28.

System Setup

- The setup menu is displayed on the fluorescent display and allows you to perform the setup procedures easily. In most situations, you will only need to set this once during the installation and layout of your home theater, and it rarely needs to be changed later.

The setup menu consists of 5 main menus ; system, input, speaker setup, CH level and parameter. These menus are then divided up into various sub-menus.

1. Turn the setup menu on.

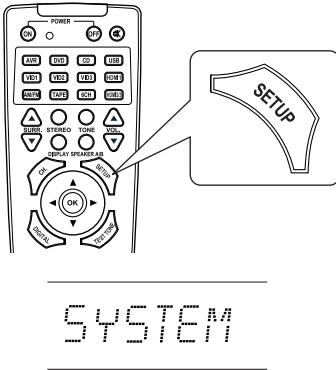

- The setup menu will be shown.
- To turn the menu off, press this button again.

2. Select the desired menu using the ▲/▼ buttons.

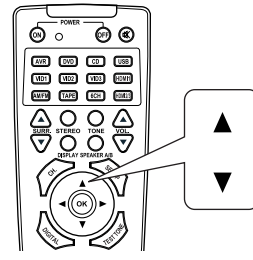

3. Confirm your selection.

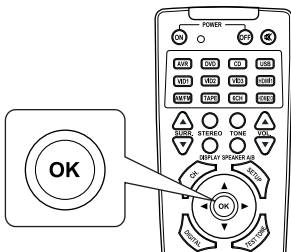

- When selecting "SYSTEM", see "SETTING THE SYSTEM" on page 34.
- When selecting "INPUT", see "SETTING THE INPUT" on page 36.
- When selecting "SPK SET", see "SETTING THE SPEAKER SETUP" on page 37.
- When selecting "CH LEVEL", see "SETTING THE CH LEVEL" on page 40.
- When selecting "PARAMTR", see "SETTING THE PARAMETER" on page 42.
- When selecting "EXIT", the setup menu will be turned off.

■ Setup menu flow

• The setup menu flow is as follows :

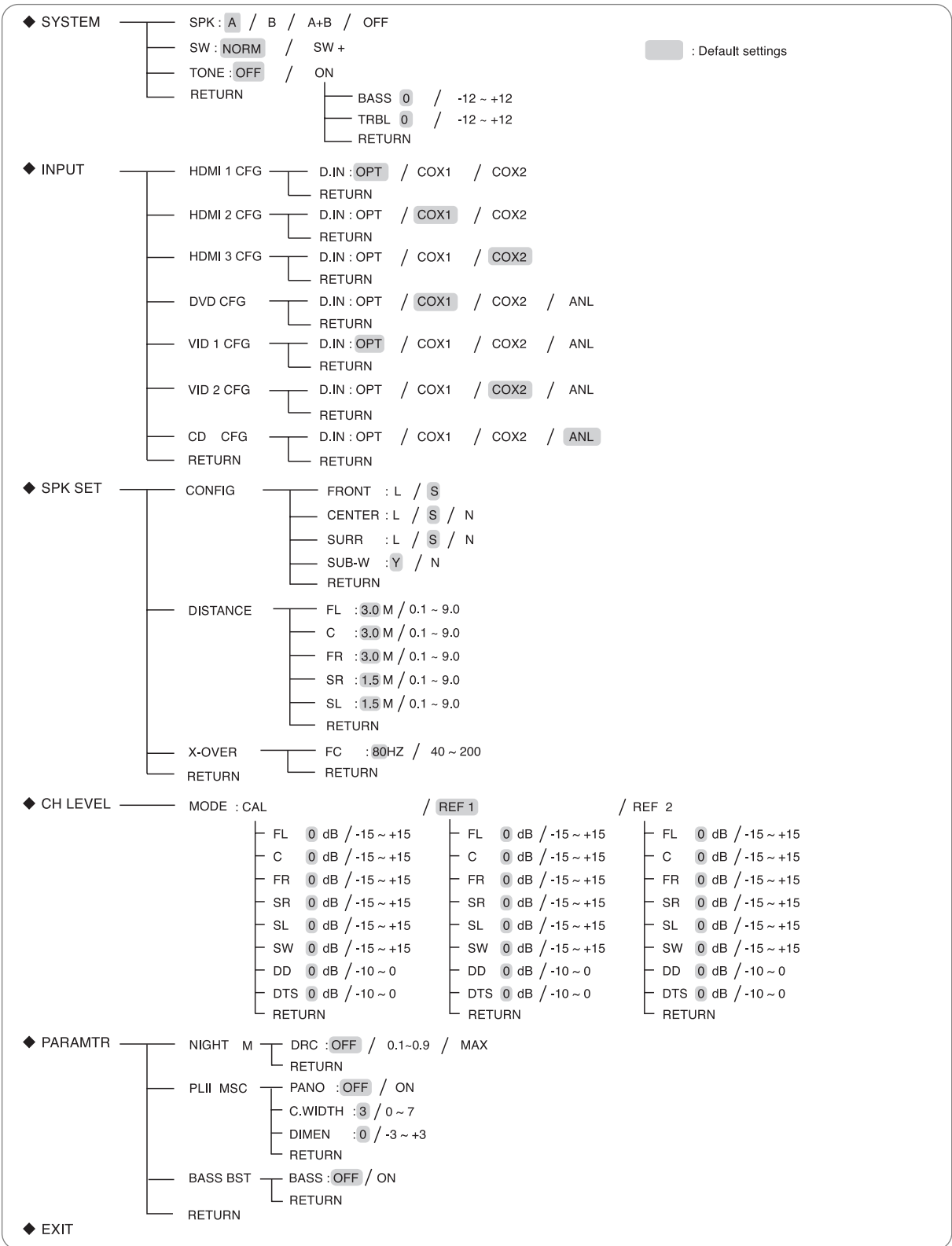

• When "RETURN" is selected in a sub-menu, it returns to the previous menu.

NOTE : During setup menu operation, only the POWER OFF button and the buttons required for system setup will function.

SETTING THE SYSTEM

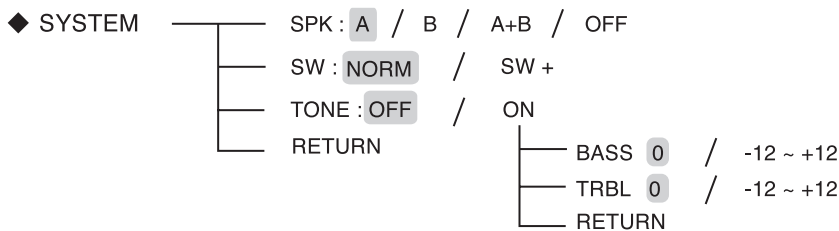

- SPK(SPEAKER) : To switch the desired speakers on.
- SW (SUBWOOFER) : To select the desired subwoofer mode.
- TONE : To adjust the tone (bass and treble) as desired.
- RETURN : To return to the previous menu.

1. Press the ▲/▼ buttons to select the desired item.

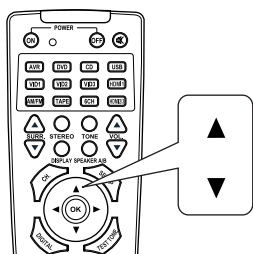

2. Press the ◀▶ buttons to set the selected item as desired

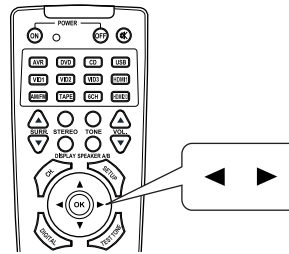

When selecting the SPEAKER mode

- A : To switch the A speakers on.
- B : To switch the B speakers on.
- A+B : To switch the A and B speakers on.
- OFF : To switch off all the speakers.

NOTE: When using the headphones for private listening, switch off all the speakers.

When selecting the SUBWOOFER mode

- "SW +" mode is effective only when program sources without LFE signals are played and "FRONT", "CENTER" or "SURR" is set to "L" and "SUB- W" is set to "Y" on the SPK SET menu. (For details, refer to "SETTING THE SPEAKER SETUP" on page 37.)

NORM : When the low frequency signals of channels set to "L" are reproduced from those channels only.



In this mode, the low frequency signals that are reproduced from the subwoofer channel is only the low frequency signals of LFE (from the multi-channel sources that contains LFE (Low Frequency Effects) channel, also called the ".1" channel) and the channels set to "S".

SW + : When the low frequency signals of channels set to "L" are reproduced simultaneously from those channels and the subwoofer channel.

In this mode, the low frequency range expands more uniformly through the room, but depending on the size and shape of the room, interference may result in a decrease of the actual volume of the low frequency range.

When selecting the TONE

OFF : To listen to a program source without the tone effect. ("DIR" indicator lights up.)



ON : To adjust the tone for your taste. ("DIR" indicator goes off.)

NOTE : When the 6CH DIRECT INPUT is selected as an input source, the TONE cannot be set to ON.

■ When the TONE is set to ON to adjust the tone (bass and treble)

① Press the OK button to enter the tone adjustment.

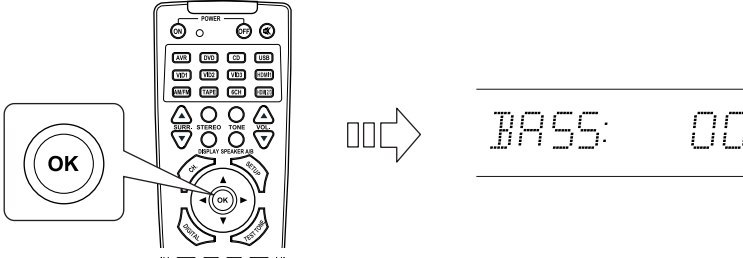

② Press the ▲/▼ buttons to select the desired tone.

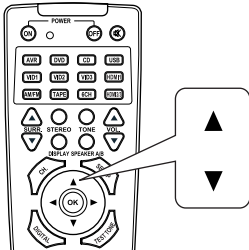

③ Press the ◀/▶ buttons to adjust the selected tone as desired.

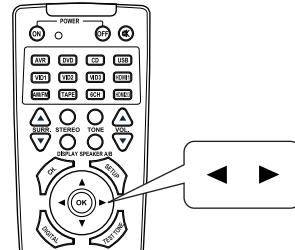

- The tone level can be adjusted within the range of -12 ~ +12 dB.
- In general, we recommend the bass and treble to be adjusted to 0 dB (flat level).
- Extreme settings at high volume may damage your speakers.
- To complete tone adjustment, repeat the above steps ② and ③.

SETTING THE INPUT

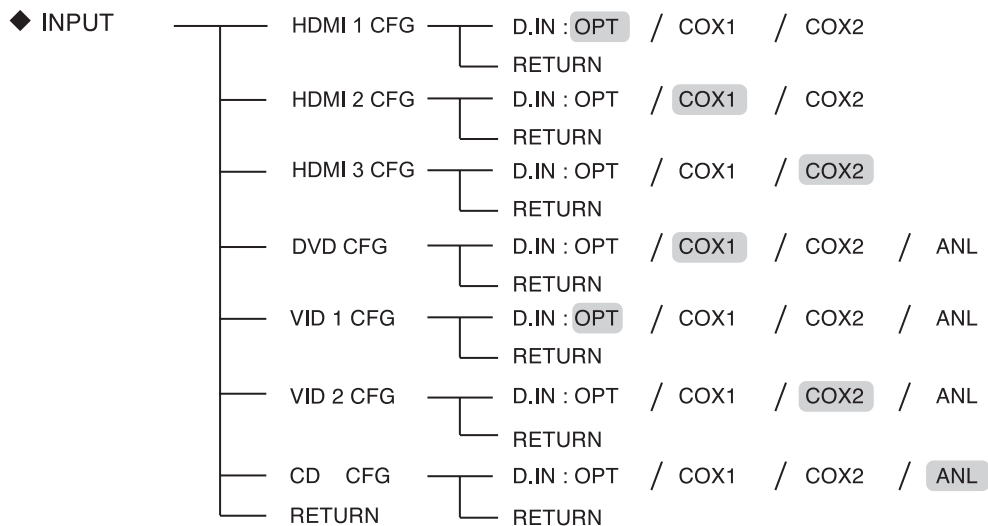

- D.IN (DIGITAL IN) : To assign the connected DIGITAL INs to the desired input.
- RETURN : To return to the previous menu.

- You should assign the connected DIGITAL INs to the desired input : CD, DVD, HDMI 1~3 or VIDEO 1 ~ VIDEO 2. (For details, refer to "CONNECTING DIGITAL INs" on page 7.)
- You can select the desired of OPT (optical), COX 1 (coaxial 1), COX 2 (coaxial 2) and ANL (analog).
- When selecting HDMI 1~3 as an input source, ANL(analog) cannot be selected.

1. Press the ▲/▼ buttons to select the desired input source, then press the OK button.

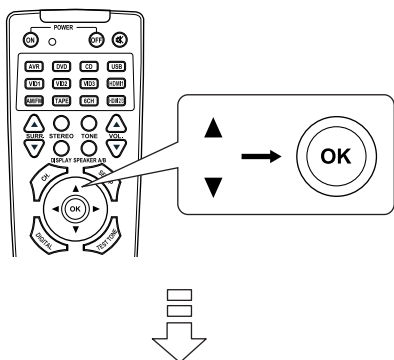

Example) When selecting the DVD

D.I.N : COX 1

2. Press the ◀/▶ buttons to set the desired signal input.

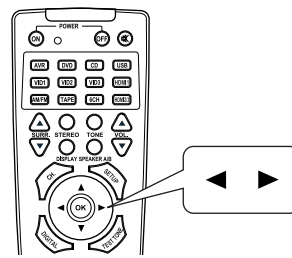

NOTE : In such a case that a DIGITAL IN is assigned to two input sources or more, when these input sources are selected, the digital audio signals can be heard from the same DIGITAL IN.

SETTING THE SPEAKER SETUP

- After you have installed this receiver and connected all the components, you should adjust the speaker settings for optimum sound according to your environment and speaker layout.
- In case you change speakers, speaker positions, or the layout of your listening environment, you should adjust the speaker settings again.

◆ SPK SET	CONFIG	FRONT : L / S
		CENTER : L / S / N
		SURR : L / S / N
		SUB-W : Y / N
		RETURN
	DISTANCE	FL : 3.0 M / 0.1 ~ 9.0
		C : 3.0 M / 0.1 ~ 9.0
		FR : 3.0 M / 0.1 ~ 9.0
		SR : 1.5 M / 0.1 ~ 9.0
		SL : 1.5 M / 0.1 ~ 9.0
	X-OVER	FC : 80HZ / 40 ~ 200
		RETURN

- CONFIG (CONFIGURATION) : To select the sizes of the speakers that are connected.
- DISTANCE: To enter the distance between the listening position and each speaker to set the delay time automatically for optimum surround playback.
- X-OVER (CROSSOVER) : To select the desired crossover frequency.
- RETURN : To return to the previous menu.

When selecting CONFIGURATION

1. Press the ▲/▼ buttons to select "CONFIG", then press the OK button.

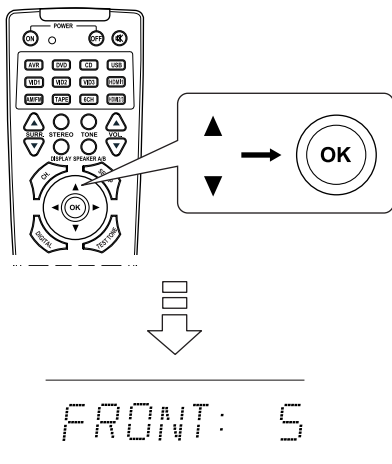

2. Press the ▲/▼ buttons to select the desired speaker.

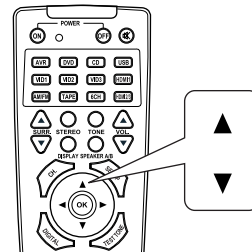

3. Press the ◀/▶ buttons to set the selected speaker as desired.

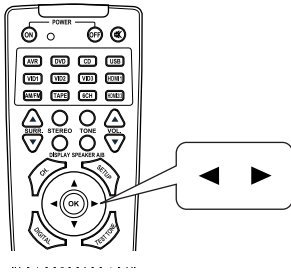

- Depending on your speaker type, you can select one of these following speaker types.
 - L(Large): Select this when connecting speakers that can fully reproduce sounds below crossover frequency.
 - S(Small) : Select this when connecting speakers that can not fully reproduce sounds below crossover frequency. When this is selected, sounds below crossover frequency are sent to the subwoofer or speakers which are set to "L (Large)" (when not using a subwoofer)
 - N(None): Select this when no speakers are connected. When this is selected, sounds are sent to the speakers which are not set to "N (None)".
 - Y(Yes)/N(No): Select the proper setting, depending on whether a subwoofer is connected or not.

NOTES :

- When speakers are set to "S (Small)", you should set their crossover frequency correctly according to their frequency characteristics. (For details, refer to "When selecting the CROSSOVER" on page 39.)
- When "SUB-W" is set to "N (No)", "FRONT" is automatically set to "L (Large)".
- When the "FRONT" is set to "S (Small)", "CENTER" and "SURR" cannot be set to "L (Large)".

4. Repeat the above steps 2 and 3 until the speakers are all set to the desired mode.

■ About speaker size

- Select "L (Large)" or "S (Small)" not according to the actual size of the speaker but according to the speaker's capacity for playing low frequency (bass sound below frequency set on the "X-OVER" menu) signals.
- If you do not know, try comparing the sound at both settings (setting the volume to a level low enough so as not to damage the speakers) to determine the proper setting.

When selecting the DISTANCE

1. Press the ▲/▼ buttons to select the DISTANCE, then press the OK button.

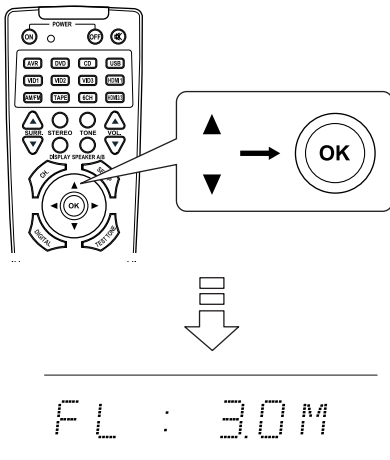

2. Press the ▲/▼ buttons to select the desired speaker.

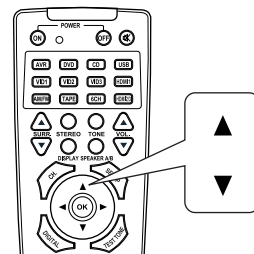

NOTE : You cannot select the speakers set to "N (None or No)".

3. Press the ◀/▶ buttons to set the selected speaker according to your distance to it.

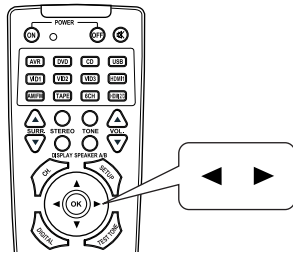

- You can set the distance within the range of 0.1 ~ 9.0 meters in 0.1 meter intervals .

4. Repeat the above steps 2 and 3 until the distances are all set as desired.

■ About the speaker distance

When enjoying multi-channel surround playback with Dolby Digital and DTS sources, etc., it is ideal that the center and surround speakers should be the same distance from the main listening position as the front speakers. By entering the distance between the listening position and each speaker, the delay times of center and surround speakers are automatically adjusted to create an ideal listening environment virtually as if the center and surround speakers were at their ideal locations respectively.

When selecting the CROSSOVER

- When speakers are set to "S (Small)", be sure to set their crossover frequency correctly according to their frequency characteristics.

1. Press the ▲/▼ buttons to select the "X-OVER", then press the OK button.

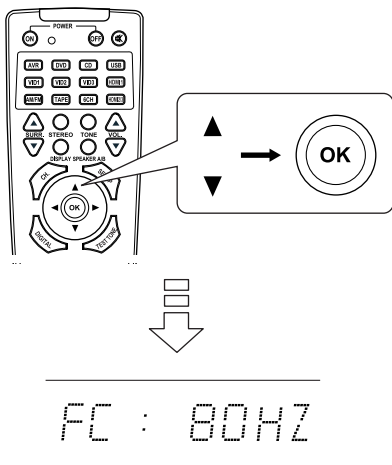

2. Press the ◀/▶ buttons to set the crossover frequency as desired.

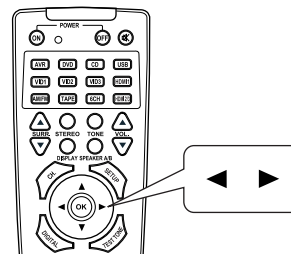

- You can adjust the crossover frequency within the range of 40 ~ 200 Hz in 10 Hz intervals.

■ About the crossover frequency

- When speakers are set to "S (Small)", low frequencies in those channels that are below the crossover frequency are output from subwoofer or front speakers which are set to "L (Large)" (when not using a subwoofer).
- Refer to the operating instructions of the speakers to be connected. If the frequency range of your speaker is 100 Hz~20 kHz, the crossover frequency should be set to 100 Hz(or slightly higher).

SETTING THE CH LEVEL

◆ CH LEVEL	MODE : CAL	/ REF 1	/ REF 2
FL	0 dB / -15 ~ +15	FL 0 dB / -15 ~ +15	FL 0 dB / -15 ~ +15
C	0 dB / -15 ~ +15	C 0 dB / -15 ~ +15	C 0 dB / -15 ~ +15
FR	0 dB / -15 ~ +15	FR 0 dB / -15 ~ +15	FR 0 dB / -15 ~ +15
SR	0 dB / -15 ~ +15	SR 0 dB / -15 ~ +15	SR 0 dB / -15 ~ +15
SL	0 dB / -15 ~ +15	SL 0 dB / -15 ~ +15	SL 0 dB / -15 ~ +15
SW	0 dB / -15 ~ +15	SW 0 dB / -15 ~ +15	SW 0 dB / -15 ~ +15
DD	0 dB / -10 ~ 0	DD 0 dB / -10 ~ 0	DD 0 dB / -10 ~ 0
DTS	0 dB / -10 ~ 0	DTS 0 dB / -10 ~ 0	DTS 0 dB / -10 ~ 0
RETURN		RETURN	RETURN

NOTE : Depending on the speaker settings ("N (None or No)"), some channels cannot be selected.

Adjusting the current channel level

- You can adjust the current channel levels as desired. These adjusted levels are just memorized into user's memory ("CAL"), not into preset memory ("REF 1", "REF 2")
- After adjusting each channel level with test tone, adjust the channel levels either according to the program sources or to suit your tastes. (For details, refer to "Adjusting each channel level with test tone" on page 21.)

1. Press the ▲/▼ buttons to select the desired channel.

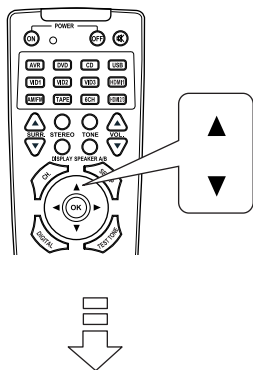

Example)
When selecting Dolby
Digital source's LFE
(Low Frequency
Extension)

DD 0dB

2. Press the ◀/▶ buttons to adjust the level of the selected channel or program source's LFE as desired.

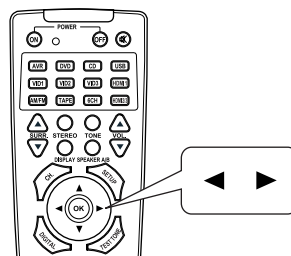

- The LFE level can be adjusted within the range of -10 ~ 0 dB and other channel levels within the range of -15 ~ +15 dB
- In general, we recommend the LFE level to be adjusted to 0 dB. (However, the recommended LFE level for some early DTS software is -10 dB.) If the recommended levels seem too high, lower setting as necessary.

3. Repeat the above steps 1 and 2 to adjust each channel level.

Memorizing the adjusted channel levels

- You can memorize the adjusted channel levels into preset memory ("REF 1", "REF 2") and recall the memorized adjustments whenever you want.

- After performing the steps 1 ~ 3 in "Adjusting the current channel level" procedure on page 40, press the OK button.

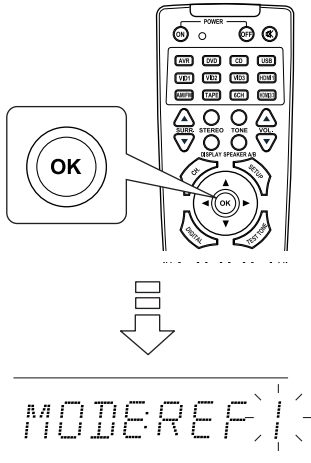

- Then "1" of "REF 1" indication flickers.

Recalling the memorized channel levels

- Press the ▲/▼ buttons to select the "MODE ~".

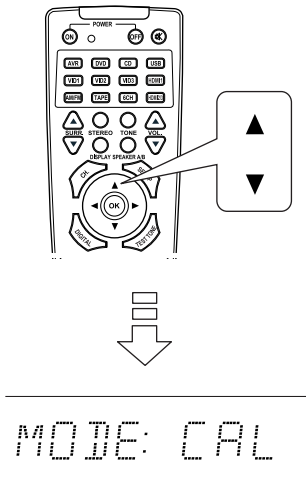

- "CAL" may be displayed instead of "REF 1" or "REF 2".

- Press the ◀/▶ buttons to select the desired preset memory, then press the OK button.

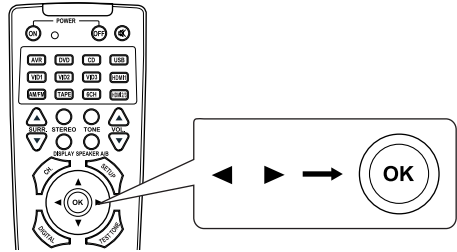

- Each time the ◀ or ▶ button is pressed, "REF 1" or "REF 2" is selected.
- The adjusted channel levels have now been memorized into the selected memory.

- Press the ◀/▶ buttons to select the desired one of REF 1 and REF 2.

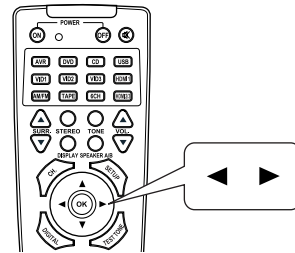

- Then the channel levels memorized into the selected preset memory are recalled.

SETTING THE PARAMETER

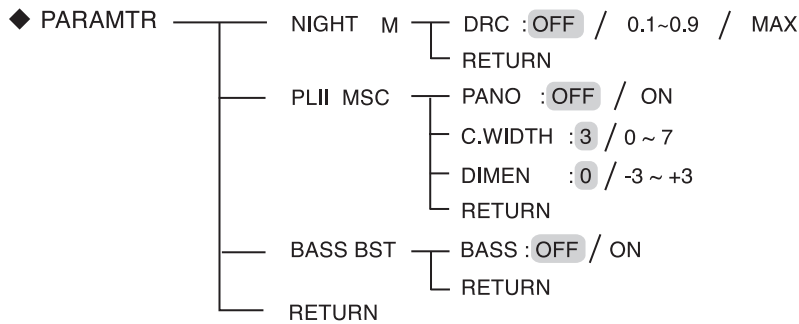

- NIGHT M (NIGHT MODE) : To adjust the dynamic range compression that makes faint sound easier to hear at low volume levels.
- PLII MSC (DOLBY PLII MUSIC) : To adjust the various surround parameters for optimum surround effect.
- BASS BST (BASS BOOST) : To enhance the bass sound for small speakers.
- RETURN : To return to the previous menu.

When selecting the NIGHT MODE

- This function compresses the dynamic range of previously specified parts of Dolby Digital or DTS sound track (with extremely high volume) to minimize the difference in volume between the specified and non-specified parts. This makes it easy to hear all of the sound track when watching movies at night at low levels.

NOTES:

- The night mode setting is valid only when the digital signals from Dolby Digital or DTS program source are being input.
- In some Dolby Digital or DTS software, the night mode setting may not be valid.

1. Press the ▲/▼ buttons to select the "NIGHT M", then press the OK button.

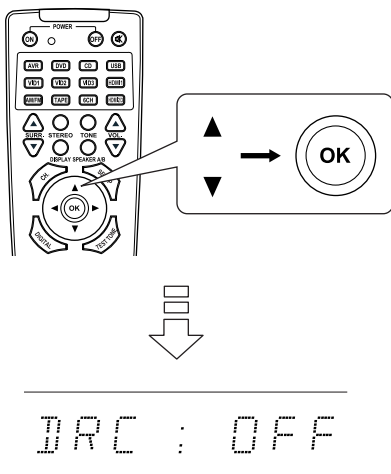

2. Press the ◀/▶ buttons to adjust the dynamic range compression as desired.

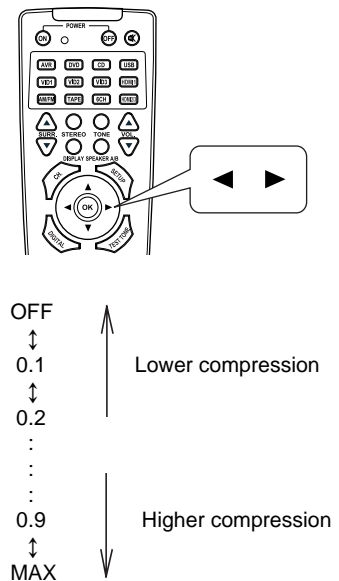

When selecting the DOLBY PLII MUSIC

• You can adjust the various surround parameters for optimum surround effect.

NOTE: The parameter settings are valid only when listening in Dolby Pro Logic II Music mode.

1. Press the ▲/▼ buttons to select the "PLII MSC", then press the OK button.

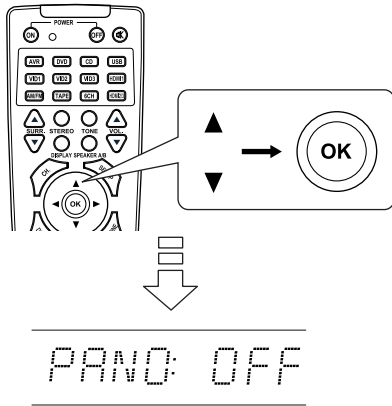

2. Press the ▲/▼ buttons to select the desired parameter.

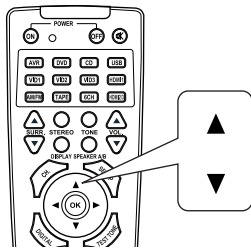

4. Repeat the above steps 2 and 3 to adjust other parameters.

When selecting the BASS BOOST

• The bass boost function enhances the bass sound for small speakers(i.e., speakers set to "S"(Small)) that are incapable of reproducing low frequencies.

NOTE: The bass boost setting is valid only when playing music files from the USB device.

1. Press the ▲/▼ buttons to select the "BASS BST", then press the OK button.

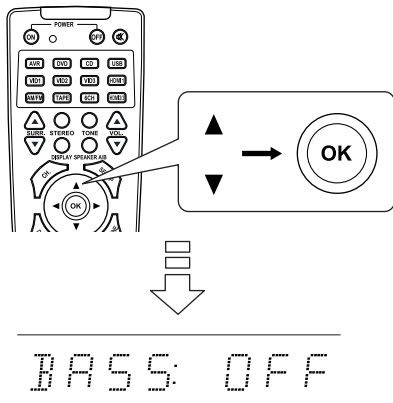

3. Press the ◀/▶ buttons to adjust the selected parameter as desired.

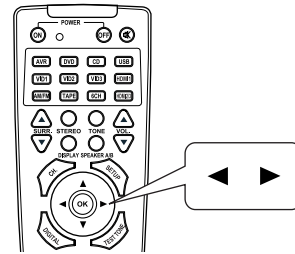

■ When selecting the "PANO (Panorama)" mode

This mode extends the front stereo image to include the surround speakers for an exciting "wraparound" effect with side wall imaging. Select "OFF" or "ON"(default value:OFF).

■ When selecting the "C. WIDTH (Center width)" control

This adjusts the center image so it may be heard only from the center speaker, only from the left/right speakers as a phantom image, or from all three front speakers to varying degrees. The control can be set in 8 steps from 0 to 7 (default value : 3).

■ When selecting the "DIMEN (Dimension)" control

This gradually adjusts the soundfield either towards the front or towards the rear. The control can be set in 7 steps from -3 to +3 (default value : 0).

2. Press the ◀/▶ buttons to select the desired mode.

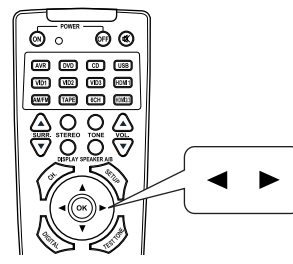

OFF : To turn off the bass boost for small speakers.

↑
ON : To enhance the bass sound.

Troubleshooting Guide

If a fault occurs, run through the table below before taking your receiver for repair.

If the fault persists, attempt to solve it by switching the receiver off and on again. If this fails to resolve the situation, consult your dealer. Under no circumstances should you attempt to repair the receiver yourself. This could void the warranty.

PROBLEM	POSSIBLE CAUSE	REMEDY
No power	<ul style="list-style-type: none"> The AC input cord is disconnected. Poor connection at AC wall outlet or the outlet is inactive. 	<ul style="list-style-type: none"> Connect the cord securely. Check the outlet using a lamp or another appliance.
No sound	<ul style="list-style-type: none"> The speaker cords are disconnected. The master volume is adjusted too low. The MUTE button on the remote control is pressed to ON. Speakers are not switched on. Incorrect selection of the input source. Incorrect connections between the components. 	<ul style="list-style-type: none"> Check the speaker connections. Adjust the master volume. Press the MUTE button to cancel the muting effect. Switch the speakers on. Select the desired input source correctly. Make connections correctly.
No sound from the surround speakers	<ul style="list-style-type: none"> Surround mode is switched off(stereo mode). Master volume and surround level are too low. A monaural source is used. Surround speaker setting is "N". 	<ul style="list-style-type: none"> Select a surround mode. Adjust master volume and surround level. Select a stereo or surround source. Select the desired surround speaker setting.
No sound from the center speaker	<ul style="list-style-type: none"> Surround mode is switched off(stereo mode). Center speaker setting is "N". Master volume and center level are too low. 	<ul style="list-style-type: none"> Select the desired surround. Select the desired center speaker setting. Adjust master volume and center level.
Stations cannot be received	<ul style="list-style-type: none"> No antenna is connected. The desired station frequency is not tuned in. The antenna is in wrong position. 	<ul style="list-style-type: none"> Connect an antenna. Tune in the desired station frequency. Move the antenna and retry tuning.
Preset stations cannot be received	<ul style="list-style-type: none"> An incorrect station frequency has been memorized. The memorized stations are cleared. 	<ul style="list-style-type: none"> Memorize the correct station frequency. Memorize the stations again.
Poor FM reception	<ul style="list-style-type: none"> No antenna is connected. The antenna is not positioned for the best reception. 	<ul style="list-style-type: none"> Connect an antenna. Change the position of the antenna.
Continuous hissing noise during FM reception, especially when a stereo broadcast is received.	<ul style="list-style-type: none"> Weak signals. 	<ul style="list-style-type: none"> Change the position of the antenna. Install an outdoor FM antenna.
Continuous or intermittent hissing noise during AM reception, especially at night.	<ul style="list-style-type: none"> Noise is caused by motors, fluorescent lamps or lightning, etc. 	<ul style="list-style-type: none"> Keep the receiver away from noise sources. Install an outdoor AM antenna.
Remote control unit does not operate.	<ul style="list-style-type: none"> Batteries are not loaded or exhausted. The remote sensor is obstructed. 	<ul style="list-style-type: none"> Replace the batteries. Remove the obstacle.

Specifications

■ GENERAL

- Power supply | 240 V ~ 50 Hz
- Power consumption | 260 W
- Dimensions (W × H × D, including protruding parts) | 440 × 141 × 350 mm
- Weight (Net) | 8.5 kg

Note: Design and specifications are subject to change without notice for improvements.

harman/kardon®

H A Harman International® Company

250 Crossways Park Drive, Woodbury, New York 11797

www.harmankardon.com

Harman Consumer Group Inc.:

2, route de Tours, 72500 Château-du-Loir, France

© 2006 Harman Kardon, Incorporated

Part No.: 5707-0000-198-0S